

Protect 2.33 2.0

Uninterruptible
Power Supply UPS

EN



CONTENTS

1. Introduction	5
1.1. Using this manual	5
1.1.1. Symbols and conventions used.....	6
1.1.2. For more information and help	7
1.1.3. Safety and instructions	7
2. Quality and standard guarantee	8
2.1. Management declaration	8
2.2. Standards.....	9
2.3. Environmental protection	9
3. Presentation.....	10
3.1. Views	10
3.1.1. Views of the equipment	10
3.1.2 Corresponding legends for the equipment views	13
3.2. Structure	15
3.2.1. Structural schema	15
3.3. Operating principle	15
3.3.1. Normal operation ⇔.....	16
3.3.2. Operation with mains failure →	16
3.3.3. Operation with inverter not active ➡	16
3.3.4. Operation in manual bypass ➡	17
3.4. Parallel operation	17
4. Installation.....	19
4.1. Important safety instructions	19
4.1.1. Battery safety instructions	20
4.1.2. Cabinet access	21
4.2. Set up and installation.....	23
4.2.1. Unpacking and content checking.....	23
4.2.2. Storage.....	24
4.2.3. Transportation to site	24
4.2.4. Location.....	25

4.3. Connection	26
4.3.1. To the mains connection, terminals (X1 to X4)	26
4.3.2. Connection of the output, terminals (X6 to X9)	28
4.3.3. UPS connection to each battery pack in cabinet, terminals (X11, X12, X23 and X47, X48, X49).....	29
4.3.4. Connection main protective earthing terminal (⊕) and protective earth bonding terminal (⊕).....	30
4.3.5. Interface relay contacts, connector (X32).....	30
4.3.6. COM-interface RS232 and RS485, connector (X31)	31
4.3.7. EPO terminals (X50)	33
4.3.8 Parallel BUS connection (X36).....	33
5. Operation.....	35
5.1. Start up	35
5.1.1. Control before start up	35
5.1.2. Start up procedure	35
5.2. Complete UPS shutdown	37
5.3. Emergency power off (EPO) operation	38
5.4. Bypass manual switch (Maintenance).....	38
5.4.1. Principle of operation	38
5.4.2. Transfer to maintenance bypass	38
5.4.3. Transfer to normal operation	39
6. Control panel and display description	41
6.1. Control panel parts	41
6.1.1. Touch Screen.....	41
6.2. Basic functions of keyboard from synoptic.....	41
6.2.1. Messages menus and classification in submenus	43
6.2.2. Menu structure	44
6.3. Screen description.....	45
6.3.1. Main level (screen menu 0.0)	45
6.3.2. UPS status control (screen menu 1.0).....	46

6.3.3. "MEASURES" level (screen menu 2.0).....	48
6.3.4. "SETTINGS" level (screen menu 3.0)	51
6.3.5. "ALARMS" level (screen menu 4.0).....	56
6.3.6. "DATA LOGGER" level (screen menu 5.0)	69
7. Maintenance, warranty and service	71
7.1. Basic maintenance guide	71
7.1.1. Battery fuses	71
7.1.2. Batteries	71
7.1.3. Cooling Fan.....	72
7.1.4. Capacitors	72
7.2. Warranty conditions	72
8. Annexes	73
8.1. General technical Specification	73
8.2 Safety Instructions	76

1. INTRODUCTION

We would like to thank you in advance for the trust you have placed in us by purchasing this product. Read this instruction manual carefully before starting up the equipment and keep it for any possible future consultation that may be required.

We remain completely at your disposal for any further information or any query you should wish to make.

Yours sincerely,
AEG Power Solutions

- The equipment here described can cause significant physical damage due to improper handling. This is why the installation, maintenance and/or fixing of the equipment described here must be done by our staff or specifically authorised personnel.
- According to our policy of constant evolution, we reserve the right to modify the specifications in part or in whole without advance warning.
- All reproduction or third party concession of this manual is prohibited without the previous written authorization of our firm.

1.1. USING THIS MANUAL

The goal of this manual is to give explanations and procedures for the installation and operation of the equipment. This manual has to be read carefully before installing and operating the equipment. Keep this manual for future consultation.

This equipment has to **be installed by qualified staff**. With the simple help of this manual, **it can be operated by personnel without specific training**.

1.1.1. SYMBOLS AND CONVENTIONS USED



Warning

Carefully read the indicated paragraph and take the stated prevention measures.



Danger of electrical discharge

Pay special attention to it, both in the indication on the equipment and in the paragraph referred in this user manual.



Main protective earthing terminal

Connect the earth cable coming from the installation to this terminal.

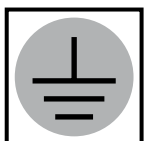

Earth bonding terminal

Connect the earth cable coming from the installation to this terminal.



Notes of information

Additional topics that complement the basic procedures.



Preservation of the environment

The presence of this symbol in the product or in its associated documentation states that, when its useful life is expired, it will not be disposed with the domestic refuse. In order to avoid possible harm to the environment, separate this product from other refuse and recycle it appropriately. Users may contact their provider or with the relevant local authorities to be informed on how and where they can take the product to be recycled and/or disposed of correctly.

1.1.2. FOR MORE INFORMATION AND HELP

For more information and/or help with the version of your specific unit, contact our Service and Technical Support (**S.T.S.**).

1.1.3. SAFETY AND INSTRUCTIONS

Together with the equipment and this “user and installation” manual, information pertaining to “safety instructions” is provided. These can be found in chapter 8.2 of this manual. Before proceeding to installation or commissioning, check that both sets of information are available. Please refer to chapter 8.2 carefully. Compliance with “safety instructions” are available for you to understand and observe. Once read, keep the safety instructions available for future reference.

2. QUALITY AND STANDARD GUARANTEE

2.1. MANAGEMENT DECLARATION

Our goal is the client's satisfaction, therefore this management has decided to establish a quality and environmental policy, by means of installation a quality and environmental management system that becomes us capable to comply the requirements demanded by the standard **ISO 9001** and **ISO 14001** and by our clients and concerned parts too.

Likewise, the enterprise management is committed to the development and improvement of the quality and environmental management system, through:

- The communication to all the company about the importance of satisfaction both in the client's requirements and in the legal regulations.
- Publicizing the quality and environmental policy diffusion and meeting the quality and environment targets.
- To carry out revisions by the management.
- To provide the needed resources.

Quality and environmental officer

The management designated person in charge of the quality and environment department, who, independent of other responsibilities, has the responsibility and authority to assure that the processes of the quality and environmental management systems are established and maintained; to inform the management about the operation of the quality and environmental management system, including areas for improvement; and to promote the knowledge of the requirements and environmental requirements at all levels of the organization.

The following process map represents the interaction among all the processes of the quality and environmental system:

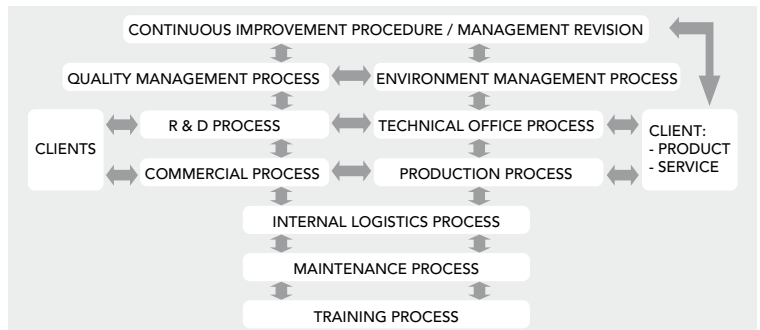

Fig.1: Process map of quality and environmental system.

2.2. STANDARDS

The UPS series product is designed, manufactured and certified in accordance with the standard **ISO 9001** of quality management systems. The **CE** marking shows the conformity to the EEC directive (quoted between brackets) by means of the application of the following standards:

- **2006/95/EC**: Low voltage directive.
- **2004/108/EC**: Electromagnetic Compatibility directive (EMC)

In accordance with the specifications of the harmonized standards:

- **EN-IEC 62040-1**: Uninterruptible power supply (UPS). Part 1-1: General and safety requirements for UPSs used in accessible areas by end users.
- **EN-IEC 60950-1**: IT equipment. Safety. Part 1: General requirements.
- **EN-IEC 62040-2**: Uninterruptible power supply (UPS). Part 2: Prescriptions for Electromagnetic compatibility (EMC).
- **EN-IEC 62040-3**: Uninterruptible power supply (UPS). Part 3: Methods of operation specification and test requirements.

The manufacturer's responsibility is excluded in the event of any modification or tampering with the product on the customer's side.

2.3. ENVIRONMENTAL PROTECTION

This product has been designed to respect the environment and has been manufactured in accordance with the standard **ISO 14001**.

Equipment recycling at the end of its useful life:

Our company is committed to use the services of authorised institutions and according to the regulations to safely dispose of the recovered product at the end of its useful life (contact your distributor).

- **Packing**: To recycle the packaging, follow the legal regulations in force.
- **Batteries**: The batteries pose a serious danger for health and the environment. The disposal of them must be carried out in accordance with the standards in force.

3. PRESENTATION

3.1. VIEWS

3.1.1. VIEWS OF THE EQUIPMENT

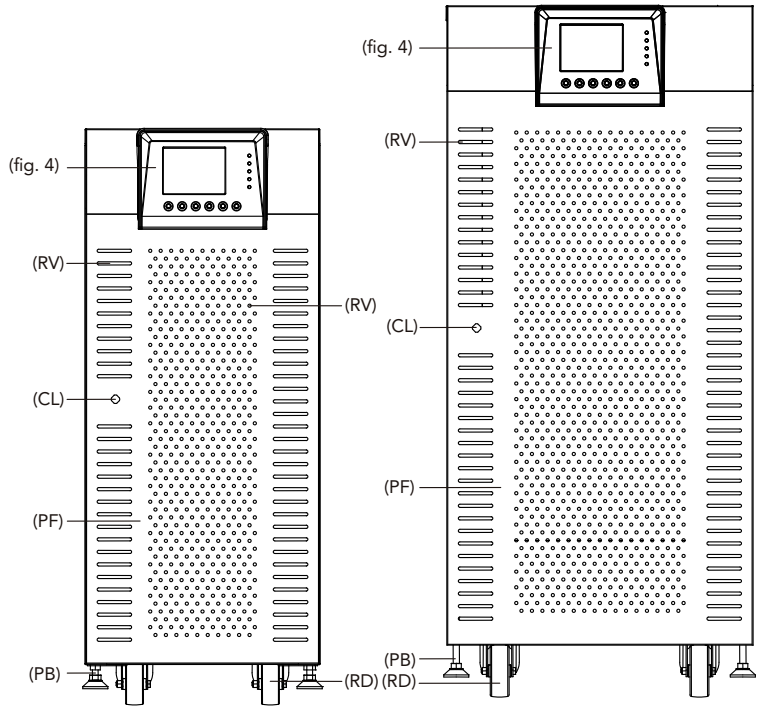

Fig.2: Cabinet front view for UPS up to 20 kVA with front door closed

Fig.3: Cabinet front view for UPS from 30 to 80 kVA with front door closed

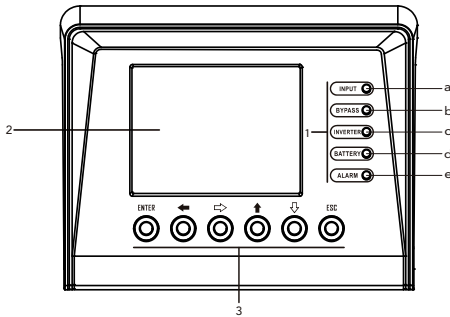

Fig.4: Control panel view

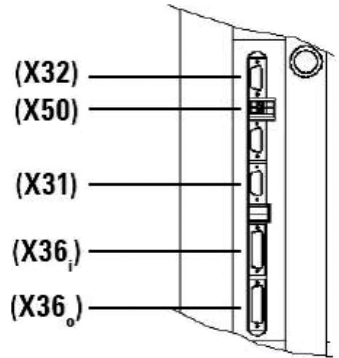

Fig.5: Communication connectors details

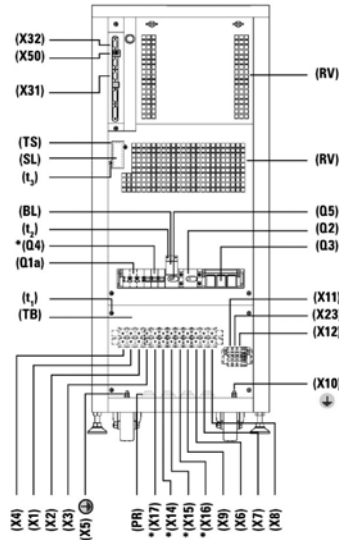
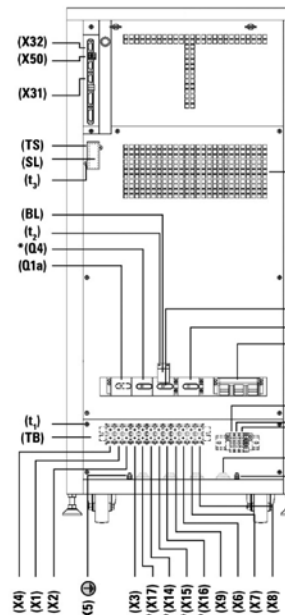

Fig.6: Cabinet front view for UPS up to 20 kVA with front door opened



*Not available for Protect 2.33 2.0

Fig.7: Cabinet front view for UPS up to 30 to 80 kVA with front door opened

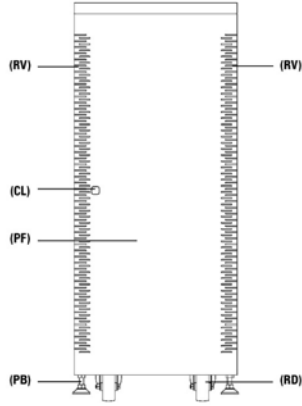

Fig.8: No. 1-3 battery cabinet front view with front door closed

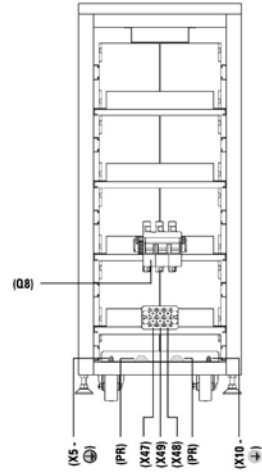

Fig.9: No. 1-3 battery cabinet front view with front door opened

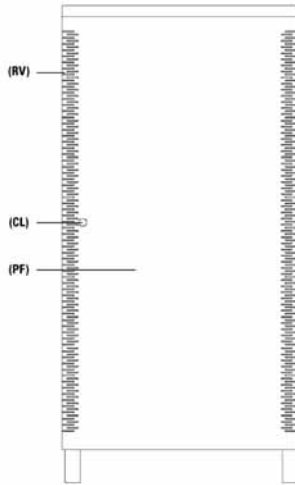

Fig.10: No. 4 battery cabinet front view with front door closed

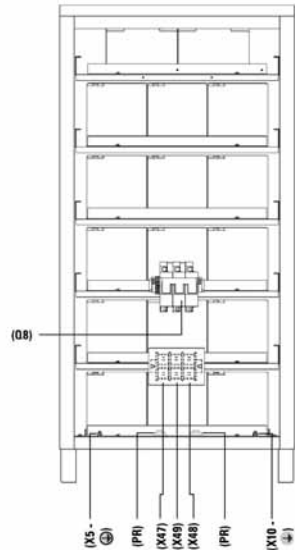

Fig.11: No. 4 battery cabinet front view with front door opened

3.1.2 CORRESPONDING LEGENDS FOR THE EQUIPMENT VIEWS

Protection and handling elements (Q):

- (Q1a) Input circuit breaker or switch according to power of the equipment
- (Q2) Output switch
- (Q3) Battery fuse holder switch with 3 fuses (models up to 40 kVA) or switch (for higher models)
- (Q4) Not available for Protect 2.33 2.0
- (Q5) Maintenance bypass switch
- (Q8) Battery fuse holder switch 3 fuses, located in the battery cabinet

Connecting elements (X):

- (X1) Phase input terminal R
- (X2) Phase input terminal S
- (X3) Phase input terminal T
- (X4) Neutral input terminal N
- (X5) Main protection earthing terminal (⊕)
- (X6) Phase output terminal U
- (X7) Phase output terminal V
- (X8) Phase output terminal W
- (X9) Neutral output terminal N
- (X10) Earth bonding terminal for load or loads and/or battery cabinet (⊕)
- (X11) Battery terminal +
- (X12) Battery terminal –
- (X23) Battery terminal N
- (X31) DB9 connector COM RS232- and RS485 ports
- (X32) DB9 connector relay interface
- (X36) Connector for connecting cable for parallel use
- (X47) Battery terminal + of external batteries cabinet
- (X48) Battery terminal – of external batteries cabinet
- (X49) Battery terminal N (middle tap) of external batteries cabinet
- (X50) Terminals for external EPO

Keyboard and optical indications control panel (PC):

- (LCD) Graphic LCD
- (ENT) Key "ENTER"
- (ESC) Key "ESC"
- (↑) Key up
- (↓) Key down
- (→) Key move to right
- (←) Key move to left
- (a) Rectifier input voltage OK LED (green)
- (b) Output voltage unit from the bypass LED (orange)
- (c) Inverter is working LED (green)
- (d) Unit working from batteries - mains failure - LED (red)
- (e) General alarm. In case of any alarm of the unit LED (red)

Other abbreviations:

- (BL) Mechanical block for manual bypass switch (Q5)
- (CL) Lock for cabinet front door
- (PB) Levelers and immobilizing elements
- (PC) Control panel
- (PF) Cabinet front door
- (PR) Cable routing or wire cones
- (RD) Scroll wheel
- (RV) Ventilation grille
- (SL) Slot for optional intelligent card
- (TB) Terminal cover
- (TS) Slot cover (SL)
- (t1) Screws fixing for terminals cover (TB)
- (t2) Screws fixing for mechanical block (BL) for switch (Q5)
- (t3) Screws fixing for slot cover (TS)

3.2. STRUCTURE

3.2.1. STRUCTURAL SCHEMA

In a single line diagram, figure 12 shows the basic structure of standard equipment and another one with separate bypass line, for a three phase input and output configuration. For any other configuration, only the quantity of cables and terminals at the input, output and bypass will vary. The internal structure of the equipment will never vary.

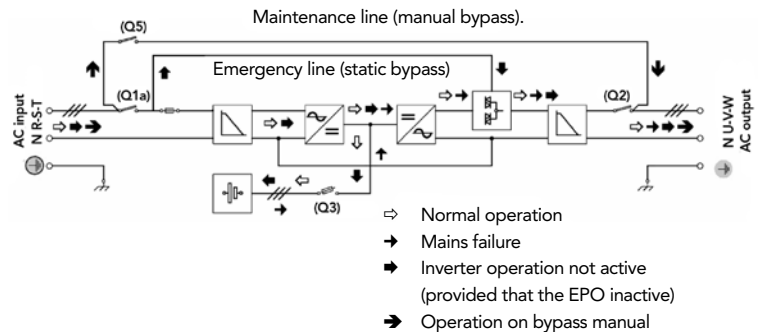

Fig.12: UPS block diagram with operating flows

3.3. OPERATING PRINCIPLE

Protect 2.33 2.0 is a double conversion system AC/DC, DC/AC with a sine wave output that gives safe protection in extreme conditions of power supply (variations in voltage, frequency, electrical noises, blackout and other power disturbances, etc...). Whatever the kind of load that has to be protected, these devices are prepared to assure quality and continuity in the electrical supply.

The operation is basically as follows:

- Rectifier, an IGBT three phase rectifier, converts the AC voltage into DC by absorbing a pure sine wave current (THD < 2,5 %*), and charging batteries at constant current / voltage.
- The batteries supply the power needed by the inverter in the event of mains failure.
- The inverter deals with transforming the voltage of the DC bus into AC by providing a sine wave, alternating output stabilized in voltage and frequency suitable for supplying the loads connected on the output.

* from 50 % load

- The basic double conversion structure is complemented by two new functional blocks, the static bypass commutator switch and the manual bypass commutator switch.
- The static bypass commutator switch connects the output load directly to the bypass network in special circumstances such as overloading or overheating and reconnects it to the inverter when normal conditions are restored.
- The manual bypass commutator switch isolates the UPS from the mains and from the loads connected on the output, so that maintenance operations may be performed in the UPS without any need to interrupt the supply to the loads.

3.3.1. NORMAL OPERATION ⇔

With the mains present, the rectifier transforms the AC input voltage into DC, raising the DC voltage to a suitable level for supplying the inverter and to charge the batteries.

The inverter deals with transforming the voltage of the DC bus into AC, providing a sine wave alternating output, stabilized in voltage and frequency to supply the loads connected to the output (Fig.12).

3.3.2. OPERATION WITH MAINS FAILURE →

In the event of mains failure or power disturbance occur, the group of batteries supplies the power needed to supply the inverter.

The inverter continues working normally, independent of the lack of mains, and the back-up time of the device depends only on the capacity of the group of batteries (Fig.12).

When the battery voltage reaches the end of back-up time, the control blocks the output as protection against a deep battery discharge.

When the mains returns and following the first seconds of analysis, the UPS operates once more as in section "Normal operation".

3.3.3. OPERATION WITH INVERTER NOT ACTIVE ➔

The inverter is inactive due to the existence of alarm conditions such as overloads, overheating, end of back-up time, etc. In this case the rectifier continues charging the batteries to maintain their optimal charge state.

The inverter is also inactive if the unit has not been started up with the keyboard. In this case, the rectifier will be inactive.

In all these cases the output voltage of the UPS is supplied by the emergency bypass line through the static bypass commutator switch (Fig. 12), provided that the EPO is inactive.

3.3.4. OPERATION IN MANUAL BYPASS →

When we wish to perform some maintenance check on the device, it may be disconnected from the mains without any need to cut the power supply to the system and affect the critical load. The UPS may be altered, only by technical or maintenance personnel. For maintenance bypass follow the special instructions for that purpose (refer chapter 5.4).

3.4. PARALLEL OPERATION

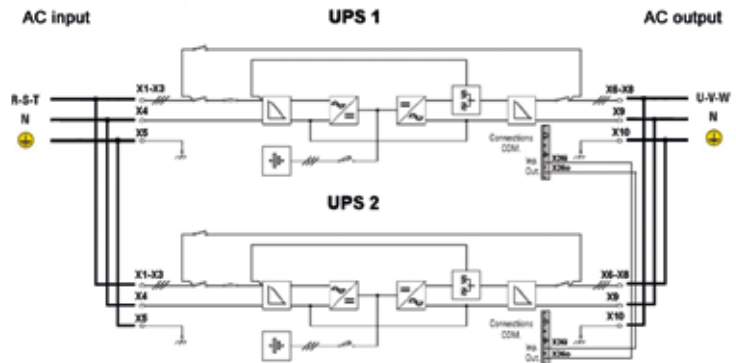

Fig.13: Single line diagram for UPS parallel system

2 UPS's can be paralleled to one UPS system for redundancy purposes or to double the maximal load level. Only identical UPS with the same ratings can be paralleled. Fig.13 shows the single line diagram of a parallel system of Protect 2.33 2.0 showing the power connections and the control bus cables. Two UPS running in parallel always do load-sharing. Parallel operation offers several advantages like higher availability or "modular" adaption of the UPS system to cover increasing power demands.

The parallel system management is based on a dynamic MASTER-SLAVE principle, where the first UPS in normal operating mode will become MASTER. It has the control of the second UPS (SLAVE).

There are two operation modes possible:

- Redundant system: As long as both UPS do not exceed the level of 50 % load one UPS is able to take over the full load if one of the UPS in the system fails. After the failed UPS was repaired it can be restarted and will recover the redundancy condition. In case of more than 50 % load per UPS the system will generate an alarm. In case one UPS fails at more than 50 % load per UPS the second UPS will take over and will run into overload. It will supply the load according to the UPS overload capability. After that condition both UPS will switch to bypass.
- Parallel system for power enhancement: Paralleling two UPS will double the maximum power. There will be no alarm "Redundancy lost".

4. INSTALLATION

- Refer to the safety instructions.
- Ensure that the data on the rating plate of the UPS match those required for installation.
- Any incorrect connection or handling may cause damage to the UPS and/or the loads connected to it. Read these instructions carefully and follow the steps indicated in the correct order.
- This UPS must be installed by qualified staff and is usable by personal with no specific training. All staff using this equipment should become familiar with the contents of this of this "Manual".
- Should a power increase be required in the future through parallel switching, consider that larger cable diameters may be required. Likewise, the additional installation of an external manual bypass switch for each device is recommended.

4.1. IMPORTANT SAFETY INSTRUCTIONS



As this is a device with class I protection against electric shocks, it is essential to install a protective earth conductor (connect earth ((⊕))). Connect the conductor to the terminal (X5), before connecting the power supply to the UPS input.

All connections in the device, including those for control (interface, remote control, ...), will be performed with the switches at rest and without any mains feed present (UPS power line cut off "Off").

It must never be forgotten that the UPS is a generator of electrical power, users must take all necessary precautions against direct or indirect contact.

Warning labels should be placed on all primary power switches installed in places away from the device to alert the electrical maintenance personnel of the presence of a UPS in the circuit. The label should contain the following or an equivalent text:

Before working on this circuit:

- Isolate Uninterruptible Power System (UPS).
- Then check for hazardous voltage between all terminals including the protective earth.



Risk of voltage feedback

Once the power supply is connected to the input of the UPS (with static bypass included or with an independent static bypass line), although the inverter is “Off” (shut-down), it does not mean that no output voltage is available at the output terminals.

To do this, it is required to switch **(Q1a)**, **(Q4)** and **(Q2)** to position “Off”. It is possible that the UPS might be supplying output voltage from the manual bypass, so this must be considered for the purpose of safety. If the output power supply of the UPS has to be interrupted in this situation, deactivate the switch **(Q5)**.

In devices with battery terminals, precautions must be taken as they are not electrically insulated from the alternating input line, and there might be dangerous voltage between the battery terminals and the ground.

4.1.1. BATTERY SAFETY INSTRUCTIONS

The manipulation and connection of the batteries shall be only be carried out and supervised by personnel with battery knowledge.

For units requested without batteries, the acquisition, installation and connection of the batteries will always be done by the **customer and it is under his responsibility**. The relevant information on the batteries (number, capacity and voltage) are indicated in the battery label pasted beside the nameplate of the equipment. **Strictly respect this data**, the battery polarity connection and the circuit diagram provided with this documentation.

The battery supply can involve the risk of electric shock and can produce high short circuit current. Observe the following preventive measures before manipulating any terminal block identified in the labeling as “Battery”:

- Disconnect the corresponding protection elements.
- When connecting a battery cabinet to the equipment, respect the cable’s polarity and color (red-positive; black-negative) indicated in the manual and in the corresponding labeling.
- Wear rubber gloves and shoes.
- Use tools with insulated handles.
- Removes watches, rings or other metal objects.
- Do not place metal tools or objects on the batteries.
- Never manipulate directly with your hands or through conducting objects, do not short the battery terminal block or the battery enclosure.
- Never short the battery terminals as it involves a high risk. It may result in damage to the equipment and batteries.

- Avoid mechanical exertions and any impacts.
- Do not open or damage the battery. Released electrolyte can be harmful to the skin and eyes.
- Do not dispose of batteries in a fire. The batteries may explode.
- In case of contact with the battery acid, wash immediately with plenty water and immediately call the nearest medical facility.
- Batteries involve a serious risk for health and for the environment.
- Their disposal should be carried out according to any existing laws.

4.1.2. CABINET ACCESS

All the UPS units and battery packs have terminals as power connection parts and a DB9 connector for the communication channel located in the inside of the equipment. Follow the steps described next to gain access to them:

- Unlock the lock (CL) with the special supplied key.
- Rotate it 45° clockwise and open the front door (PF) completely.
DB9 connectors from communication ports and terminals for remote EPO button will be revealed.
- Remove the screws (t1), which fix the terminal cover (TB) inside of the cabinet and remove it; the power terminals will be revealed.
- The connecting cables can be connected to the terminals located below the clamps and can be fixed to the aluminum rail.
- Once the connection of the UPS is complete, replace the cover (TB) and close the door (PF) with the lock (CL).

The cable cross section of the bypass, input and output lines shall be determined from the maximum currents for the two first and from nominal ones for the output, by respecting the local and/or country low voltage electro-technical standards. To calculate the cross cable sections, take the Figures of the current as stated in table 1 depending on the model and nominal voltage value of the UPS. In the nameplate of the equipment are printed the nominal currents as stated in the safety standard EN-IEC 62040-1.

Safety characteristics:

- For the input power failure circuit breaker Type B.
- For the output (supply loads) , circuit breaker with tripping characteristics C.

Minimum currents are stated in table 1 depending on the model and nominal voltage value of the UPS.

The cross sections of all of the connecting cables must in each case be sized according to the fuse selected.

In cases where added input, output or bypass peripherals to the UPS (e.g. transformers or autotransformers) currents are stated in the nameplates of the peripherals and must be taken into account in order to use suitable cross sections. Always respect the local and/or national low voltage electro-technical regulations.

PROTECT 2.33 2.0

Equipment power (kVA)	3 x 380 V			3 x 400 V			3 x 415 V		
	Input	Output	Bypass	Input	Output	Bypass	Input	Output	Bypass
10	15	15	-	14	15	-	14	14	-
15	22	23	-	21	22	-	20	21	-
20	30	30	-	28	29	-	28	28	-
30	44	45	-	43	43	-	40	41	-
40	59	61	-	57	58	-	53	55	-
60	89	91	-	85	87	-	80	82	-
80	118	122	-	113	116	-	107	110	-

Table 1: Input, output and bypass currents for standard single phase Protect 2.33 standard systems

If isolation transformers are present in the installation at the input and/or output of the UPS, they have to be fitted in with protection against indirect contacts (earth leakage breaker) at the output of each transformer. Electrically insulated of the transformer will impede the tripping of protection installed at the primary winding of the transformer in cases where an short circuit in the secondary winding (output of isolation transformer) may occur.

Note that all neutral terminals for input, output and battery are connected inside the UPS.

The cable routing or housing passages supplied fitted to the metal structure are those recommended to correctly fix the input, output and bypass wires with the sections determined by the national low voltage electro-technical regulations in accordance with the currents of the device.

If these sections should have to be changed for any reason, this should be implemented with a separate distribution box and the sections indicated should be maintained from the device to the distribution box.

In standard equipment up to 40 kVA, batteries are supplied inside the UPS enclosure and for higher power rates they are supplied in a separate cabinet. By default, the UPS has a battery fuse-holder switch (**Q3**) with 3 fuses for models up to 40 kVA or battery switch (**Q3**) for models with higher power rate.

From 60 kVA upwards, no UPS internal batteries are installed, instead you will find a circuit breaker (**Q8**) in the battery cabinet. Fuses are included in the delivery of the UPS. Open the fuse box (**Q3**) and (**Q8**) and install the three fuses. Connect the battery with the UPS and then follow the startup procedure prompted via the UPS display.



IMPORTANT FOR YOUR SAFETY: Do not turn the battery fuse holder switch or switch (**Q3**) located in the equipment or its equivalent (**Q8**) in the battery cabinet to “On” (Close) until the equipment is switched on completely, because it can cause irreversible damage to the equipment or accidents.

4.2. SET UP AND INSTALLATION

4.2.1. UNPACKING AND CONTENT CHECKING

On receiving the device, make sure that it has not suffered any damage during transport. Make all damage claims to your supplier or to our company. Check the data in the nameplate, which is fixed inside the front door (**PF**) and that it corresponds to that specified in the purchase order. To check this, it will be necessary to unpack the UPS. If this is not possible, any non-conformity must be sent at the earliest possible date, quoting the device manufacturing number and any references on the delivery remittance.

When the device has been accepted, it is best to pack the UPS away once more until it is to be commissioned in order to protect it from any possible mechanical knocks, dust, dirt, etc.

The packaging of the device consists of a wooden pallet, a cardboard or wooden surround (depending on the case), expanded polystyrene corner pieces, polyethylene sleeve and band. All are recyclable materials and should therefore be disposed of according to current regulations. However, we recommend that the packaging should be kept in case its use is necessary in the future.

To unpack, cut the bands on the cardboard surround and remove it from above.

If the surround is made of wood; remove the corner pieces and the plastic sleeve first. The UPS will be unpacked on the pallet, to lower it, suitable means (fork truck, crane, hoist) must be used that can operate within the safety tolerance limits for the approximate weights displayed in tables 5 and 6 (Page 73 – 75).

4.2.2. STORAGE

Equipment should be stored in a dry, ventilated place protected from rain, splashing water and chemicals. It is recommended to store the UPS and batteries in their original packing. This offers the best protection during transport and storage.

If ordered with the UPS, closed lead accumulators are built into the UPS or the battery cabinet. To ensure problem free operation of the 10 – 20 kVA equipment you should not store for longer than 3 months and absolutely no longer than 6 months.

If longer storage is required, the batteries must be recharged after the aforementioned periods

Store batteries or equipment with built-in batteries at 20 – 25 °C.

Deviation from this may result in a reduction of maximum storage availability.

4.2.3. TRANSPORTATION TO SITE

All UPSs are fitted with rollers to facilitate transport to site. Be sure to observe tables 5 and 6 (page 73 – 75) for indicated weights in the selection of an appropriate site and the selection of transport route (floor, elevators, stairs etc.)

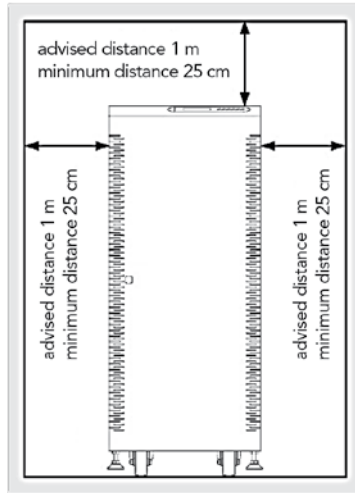

Fig.14: Front view UPS location for single unit

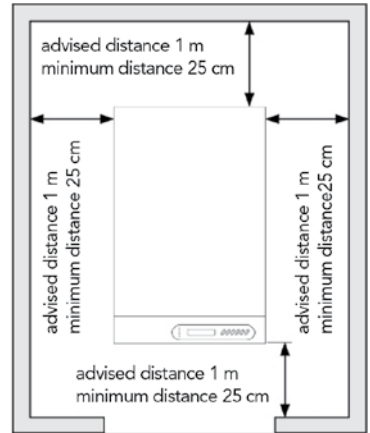

Fig.15: Top view UPS location for single unit

4.2.4. LOCATION

The security instructions indicate that it is necessary to leave a minimum of 25 cm around the equipment for ventilation (2 UPS devices in parallel operation should be set 50 cm apart from each other. See Fig.14 and 15.) Nevertheless, we recommend to leave another 75 cm additional space to facilitate maintenance of the equipment or technical service intervention in event of a breakdown.

The UPS may be put in any place as long as the safety instruction requirements are fulfilled and the weights are considered as indicated in table 5 and 6.

The UPS includes 2 leveling elements (**PB**) located near the front castors, which serve to immobilise the unit once it is in place.

Open the front door (**PF**) of the cabinet and proceed as follows:

- By hand, loosen the leveling elements (**PB**) by turning them anti-clockwise until they touch the floor. Then, using a spanner, continue loosening until the castors are raised off the floor by a maximum 0.5 cm, ensuring that it is level.
- Close the door (**PF**).

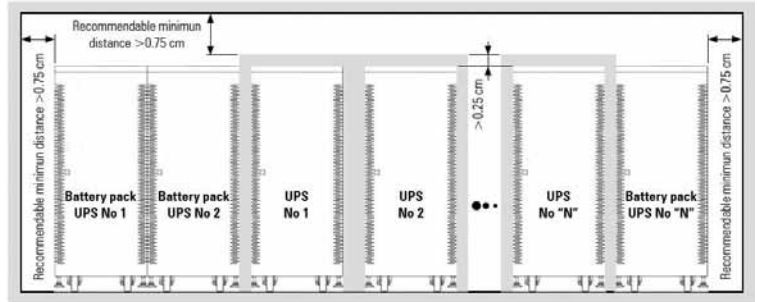

Fig.16: Front view for parallel system

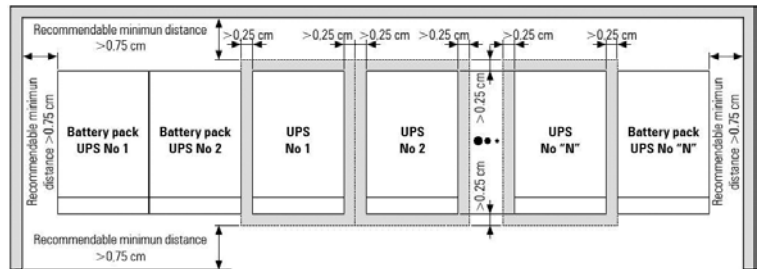

Fig.17: Floor view for parallel system

4.3. CONNECTION

4.3.1. TO THE MAINS CONNECTION, TERMINALS (X1 TO X4)

As this is a device with class I protection against electric shocks, it is essential to install a protective earth conductor (connect earth (⊕)). Connect the conductor to the terminal (X5), before connecting the power supply to the UPS input.

In accordance with safety standard EN-IEC 62040-1, installation has to be provided with a "feedback protection" system (e.g. a contactor) which will prevent the appearance of voltage or dangerous energy in the input mains during a mains fault (see Fig.18 and respect the wiring diagram of "feedback protection").

There can be no deviation in the line that goes from the "feedback protection" to the UPS, as the standard safety would be infringed.

Warning labels should be placed on all primary power switches installed in places



away from the device to alert electrical maintenance personnel to the presence of a UPS in the circuit.

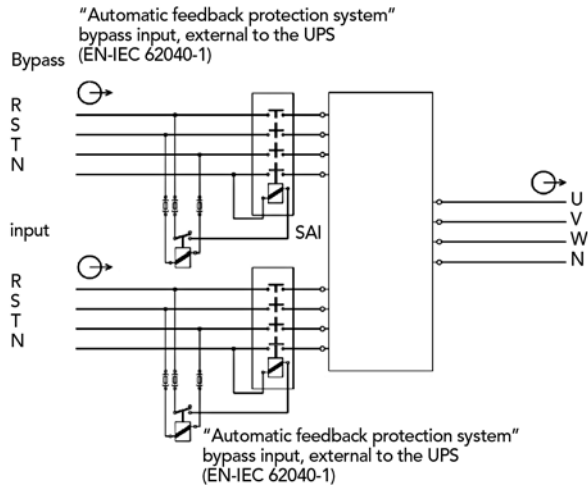

Fig.18: Block diagram for the «feedback protection» application, for the different configurations

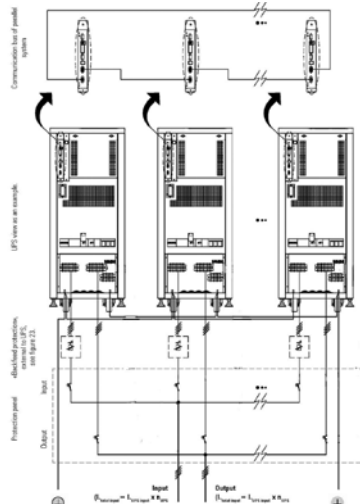

Fig.19: Single line diagram of parallel system connection(UPS) with protection panel and feedback protection

The label should contain the following or an equivalent text:

Before working on this circuit:

- Isolate Uninterruptible Power System (UPS).
- Then check for Hazardous Voltage between all terminals including the protective earth.



Risk of voltage feedback

To connect the mains cables to the respective terminals according to configuration of the available equipment.

Connection to the mains:

Connect the power supply cables N-R-S-T to the input terminals **(X4)**, **(X1)**, **(X2)** and **(X3)**, respecting the order of neutral and phases indicated on the label of the device and in this manual. If the order of the phases is not respected, the UPS cannot be started and displays an error message.

When there are discrepancies between the labeling and the instructions in this manual, the label will always prevail.

4.3.2. CONNECTION OF THE OUTPUT, TERMINALS (X6 TO X9)



As this is a device with class I protection against electric shocks, it is essential to install a protective earth conductor (connect earth (⊕)). Connect the conductor to the terminal **(X5)**, before connecting the power supply to the UPS input.

To connect the output cables to the respective terminals according to configuration of the available equipment.

Connection to the output:

Connect the load cables N-U-V-W to the output terminals **(X9)**, **(X6)**, **(X7)** and **(X8)**, respecting the order of neutral and phases indicated on the label of the device and in this manual. If the order of the phases is not respected, the UPS cannot be started and displays an error message.

When there are discrepancies between the labeling and the instructions in this manual, the label will always prevail.

It is recommended that a connected load over an external distribution over multiple (min. 3) automatic circuit breakers share 1/3 of the maximum UPS nominal output current. If one of these outlets short circuits, then the

corresponding circuit breaker should trigger without affecting the supply of the remaining outlets (selective).

4.3.3. UPS CONNECTION TO EACH BATTERY PACK IN CABINET, TERMINALS (X11, X12, X23 AND X47, X48, X49)



As this is a device with class I protection against electric shocks, it is essential to install a protective earth conductor (connect earth (⊕)). Connect the conductor to the terminal (X5), before connecting the power supply to the UPS input.



IMPORTANT FOR YOUR SAFETY: Do not turn the battery fuse holder switch or switch (Q3) located in the equipment or its equivalent (Q8) in the battery cabinet to "On" (Close), until the equipment prompts you during the startup procedure via the display, because it can cause irreversible damage to the equipment or accidents because the engineer is exposed to ELECTRICAL DISCHARGE DANGERS. The UPS prompts before connection with the battery cabinet.

UPS connection with battery pack will be implemented with the supplied trunk cable by connecting one side to terminals (X11), (X23) and (X12) of the UPS and the other one to terminals (X47), (X49) and (X48) on the battery pack. Always respect the stated polarity in the labeling of each part and in this manual. The color of the cables (red for positive, black for negative, blue for middle tap (N) and green-yellow for earth bonding), see Fig. 20.

Turn off multiple battery packs in parallel. Firstly connect the black wire from the negative terminal of the UPS to the negative terminal of the first battery pack and then from there to the others. Proceed with the cables (positive: red, center tap: blue, protective earth, green-yellow) accordingly.



Electrical discharge danger. If after starting up the UPS, it is required to disconnect the battery cabinet, the equipment has to be completely shutdown (see section 5.2). Turn off the battery fuse holder switch (Q8) located in the battery cabinet and/or fuse holder switch or switch (Q3) located in the UPS. Wait at least 5 min. until the filter capacitors have been discharged.

4.3.4. CONNECTION MAIN PROTECTIVE EARTHING TERMINAL (⊕) AND PROTECTIVE EARTH BONDING TERMINAL (⊕)



As this is a device with class I protection against electric shocks, it is essential to install a protective earth conductor (connect earth (⊕)). Connect the conductor to the terminal (X5), before connecting the power supply to the UPS input.

Make sure that all the loads connected to the UPS are only connected to the protective earth bonding terminal (⊕). By not restricting the earthing of the load or loads and/or the batteries case/s or cabinet/s to this **single point**, can lead to ground loops which can affect operational safety.

All of the terminals identified as protective earth bonding (⊕), are joined together, to the main protective earthing terminal (⊕) and to the frame of the device.

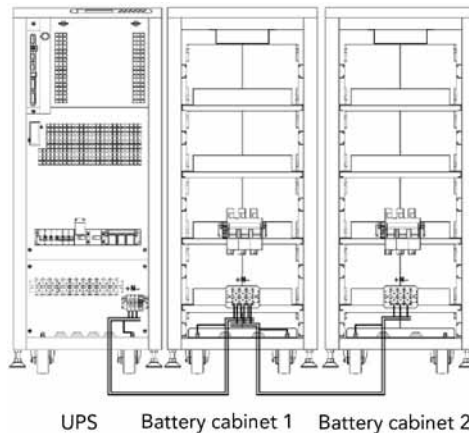

Fig.20: Connection example between a UPS and two battery cabinets

4.3.5. INTERFACE RELAY CONTACTS, CONNECTOR (X32)



The remote signal lines operate over low voltage. To ensure safe and problem free communication, install at a safe distance from the power supply lines to the UPS.

The built in relays provide a digital signal over a potential free contact.

The permissible contact load is 6 A 30 VDC or 6 A 100 VAC. Supplemental to the DB9 connector you will find parallel screw terminals on the communication board. Remote signaling operates over five output relays (one is adjustable), the

common ground is connected to pin 5. Furthermore, an input signal can be used to shut down the UPS (5 VDC – 12 VDC.)

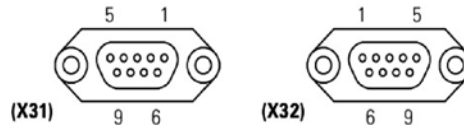

Fig.21: Connector DB9 (X31) & (X32)

PIN-OUT NO.	DESCRIPTION	N.C.-N.O. POSITION
1	Shutdown signal +	-
2	Shutdown signal –	-
3	Configurable	Not connect
4	Discharge - Mains failure	N.C. ¹
5	Common	-
6	Equipment in Bypass	N.O. ²
7	Low battery	N.O.
8	General alarm	N.O.
9	Discharge - Mains failure	N.O.

¹ N.C.: Normally closed contact. On the alarm having activated the contact is opened.

² N.O.: Normally open contact. On the alarm having activated the contact is closed.

Table 2: Alarms interface to relays connector DB9 (X32)

4.3.6. COM-INTERFACE RS232 AND RS485, CONNECTOR (X31)

The serial communications interface operates over low voltage. To ensure safe and trouble-free communication, install at a safe distance from the power supply lines to the UPS.

The X31 DB9-connector is used for communication to RS232 or RS485 standard connectors. Both standards cannot be used simultaneously.

Both channels are in use for connecting the UPS with any machine or devices that has this standard bus. The RS232 consists of the transmission of serial data, so it is possible to send a large amount of information through a communication cable of just 3 wires.



Physical structure of the RS232.

- Pin-out
 - Pin 2. RXD. Serial data reception.
 - Pin 3. TXD. Serial data transmission.
 - Pin 5. GND. Signal mass.
- Communication protocol of the RS232.

The communication protocol used is of "MASTER/SLAVE" type.

The computer or computer system ("MASTER") asks about a certain data, and the UPS ("SLAVE") answers immediately with the required data. Firstly it will be programmed the communication channel of the computer with the same parameters as the communication channel of the UPS. Then we will be prepared to start the communication and therefore send the UPS the first question. If we have any problem in the middle of the communication, it will be advisable to repeat the channel initialization sequence.

Physical structure of the RS485.

Unlike other serial communication links, this uses only 2 wires (pins 4 and 9 of the female DB9 connector) to perform the dialogue between the systems connected to the network. The communication will be established by sending and receiving signals in differential mode, which gives the system great immunity to noise and a long reach (approx. 800 m).

- Pin-out
 - Pin 4. Output signal A (+)
 - Pin 9. Output signal B (-)
- Communication protocol

The communication protocol of the RS485 channel is developed to enable the UPS to communicate with other computer systems that use the same bus.

The communication parameters RS232 and RS485 are the following:

- Communication speed: 1200, 2400, 4800, 9600 or 19200 Baud.
- No. information bits: 8 Bits.
- No. stop bits: 1 or 2 stop bits.
- Parity bit: - Even, Odd

4.3.7. EPO TERMINALS (X50)

The equipment has two terminals ready for external remote (Emergency Power Off (EPO)).

In case where there is a requirement to install a switch or button (EPO), the cable bridge that closes the circuit has to be removed from terminal strip (X50).

The switch or button (EPO) has to open the circuit between the terminal strip (X50) to activate the emergency shutdown. To restore the UPS to normal mode, reverse the position of the switch or button (EPO), -close the circuit in terminal strip (X50).

To understand the operation of (EPO), see section 5.3 of this manual.

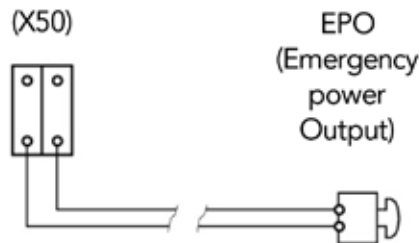

Fig.22: Terminals for connection of external push-button (EPO), property of the user

Note: In a parallel system there is an emergency stop switch to one of the two UPS devices. Detailed information on emergency shutdown can be found in chapter 5.6.

4.3.8 PARALLEL BUS CONNECTION (X36)

This section is only relevant for parallel systems.

- For the correct parallel operation both UPS communicate to each other via the parallel BUS. For redundancy purposes the BUS connection consists of 2 cables which are connected in a loop.
- Connect the parallel BUS connection after all power connections have been done. In the accessory of each UPS you can find one 5 meters, 15-pole parallel BUS cable (HDB 15 connector male/female). If you connect 2 UPS to one parallel system each UPS comes with one cable.
- Connect X36o of UPS 1 to X36i of UPS 2 and X36i of UPS 1 to X36o of UPS 2. An additional termination of the connection is not needed.

- Fix the BUS cables to the bottom of the UPS using the plastic clips below the communication interfaces.

Note: Always use the original lines to ensure trouble free parallel operation.

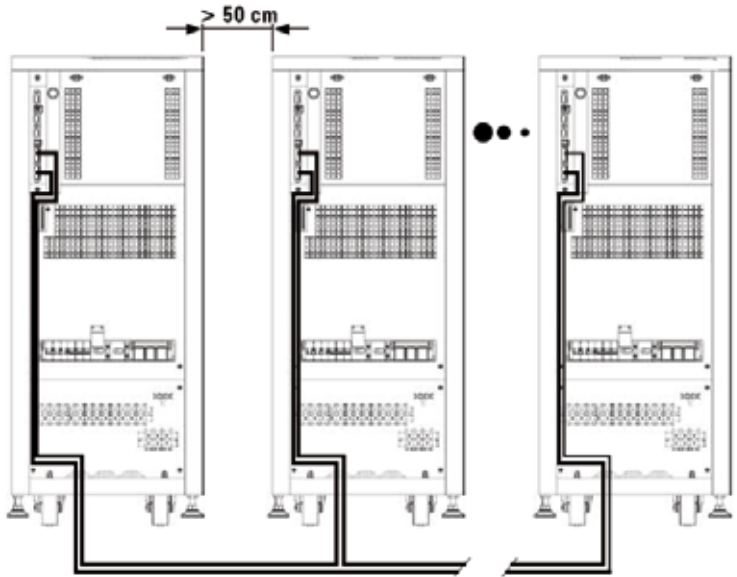

Fig.23: Parallel BUS Connection

5. OPERATION

Note: The following descriptions relate to operation of the UPS using the keys below the display screen. Operation can also be carried out using the touchscreen capability, just type in the appropriate files or text.

5.1. START UP

5.1.1. CONTROL BEFORE START UP

Ensure that all the connections have been made correctly and are sufficiently tight, respecting the labeling of the device and the instructions in chapter 4. "Installation and wiring of the unit".

Check that the UPS switches and the battery cabinet or cabinets are turned off (position "Off").

Be sure that all the loads are turned "Off".

5.1.2. START UP PROCEDURE

It is very important to operate "start-up" in the established order and to considering the following instructions.

If you start up a UPS in a parallel system, the written procedures apply to both UPS devices. You can use the procedure described below step by step for the first UPS and then for the 2nd UPS until you see the message "Close battery switch!" Now you can close both battery switches. It is irrelevant which UPS starts first.

If the UPS connects to an external battery cabinet, set the fuse holder switch of the battery cabinet (**Q8**) to "On".

If the power supply to the UPS has a general switch, set the general switch of the header board to "On".

Turn the input switch (**Q1a**) to "On" position. The display of the Control Panel (PC) will be turned on automatically.

If the following alarm message appears on the Control Panel Display ...

PHASE REVERSE INPUT POWER

... and an audible alarm sounds, the UPS cannot be started because of incorrect input phase sequence. Disconnect the input switch (Q1a) and the general cut-off of the header board, swap the phases of the input terminals of the UPS according to the labeling and repeat the start-up process described previously.

At this point, with no alarm active, green LED indications of input voltage OK, and orange LED indication of Unit on Bypass should light ((a), (b) from Fig.25).

Turn the output switch (Q2) to "On". It is now powered by the built in Thyristor supply voltage

Start up the inverter. The start-up operation will be done through the keypad of the control panel ((3) from Fig.25). Select "CNTL" and press (ENT) into control submenu (screen 1.0), and then select "ON" and press (ENT) once. You will get to screen 1.1, asking you to start the unit up "yes" or "no", you can select "Yes" by pressing (ENT). See following screen diagram (Fig.24).

After a few seconds, the UPS will be running (rectifier working, inverter working), and the output will be supplied from the inverter.

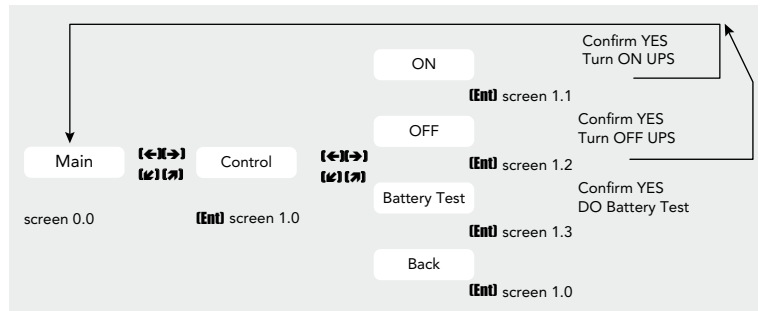

Fig.24: Procedure start-up/shutdown

Before continuing, be sure that the LED indication (c) Inverter is working and is it (green), and (b) Unit on Bypass is turned OFF (see Fig.25).

Once the rectifier is completely working, it initiates a process of equalization (DC bus voltage starts to equalize with battery voltage). After a few seconds (depending on the battery level), an alarm message like this will be displayed:

CLOSE BATTERY SWITCH

...it indicates that the equalizing process has been finished, and at this moment the battery fuse holder switch or switch of the UPS (Q3) can be turned on.

DO NOT TRY to close any battery fuse holder switch at any other moment, because this operation could damage the equipment and/or possibly cause accidents. They can only be turned on by following the previous steps.

Start up the loads to be supplied in a progressive way. The system is started up completely, and the loads are protected through the UPS.

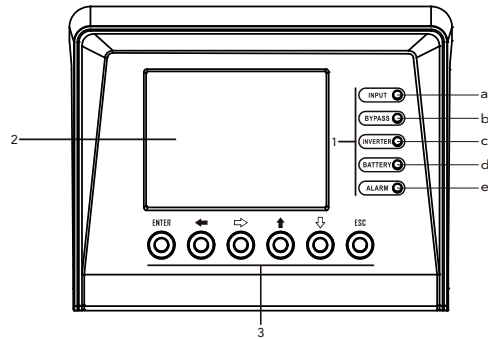

Fig.25: LED indications control panel (PC)

5.2. COMPLETE UPS SHUTDOWN

- Shutdown the loads.
- If the system has outgoing distribution protection, switch them "Off".
- Shutdown the inverter. Through the keypad of the control panel ((3) from Fig.25), go down to "CNTL" submenu (screen 1.0), and select "OFF". You will get to screen 1.2, asking you to shut down the unit by pressing (ENT), see Fig.24.
- Turn the output switch (Q2) to "Off" position.
- Set the input switch (Q1a) to "Off" position.
- Turn fuse holder switch from battery cabinet (Q8) and/or battery fuse holder switch or switch from UPS (Q3), to "Off".
- Cut the power supply of the UPS and the bypass with the cut-off or general switch on the header board. The system will be completely deactivated.

Electrical discharge hazard. If, after shutdown of the equipment, it is necessary to disconnect the separate battery pack/s, wait several minutes (5 min. approx), until the electrolytic capacitors have been discharged.

The equipment is completely shut down.



5.3. EMERGENCY POWER OFF (EPO) OPERATION

Emergency Power Off (EPO) is equivalent to a complete unit system halt:

- All UPS converters are turned off (rectifier and inverter off).
- No output voltage is supplied to the loads.

See table below for operation:

E.P.O. FUNCTION	Terminals (X50). Normally closed circuit by means of the provided cable bridge (it allows an external switch (EPO)).
ACTIVATION (PERFORM SYSTEM HALT)	Remote button or switch has to be opened permanently in terminal strip (X50).
RETURN TO NORMAL-MODE.	The equipment has to be shut down and de-energized completely (turn off all switches), wait until DC bus is discharged (all LEDs and LCD have to be turned off). The equipment has to be started up according to section 5.1.2. "Start-up procedure".

Table 3: Emergency Power Off (EPO) operation

Note: In parallel mode it is sufficient, when the emergency shutdown is activated for one UPS.

5.4. BYPASS MANUAL SWITCH (MAINTENANCE)

5.4.1. PRINCIPLE OF OPERATION

The integrated manual bypass of the UPS is a very useful element, but unwarranted use can have irreversible consequences both for the UPS and for the loads connected to its output. It is therefore important to handle it as described in the following paragraphs.

5.4.2. TRANSFER TO MAINTENANCE BYPASS

Note: The bypass switch connects the load at the electrical output before the input switch (Q1a) and after the output switch (Q2). In practice, the input switch is combined directly with the output terminals. If you switch off all of the other switches after switching on the bypass switch, the UPS is internally without power (neutral conductors are not connected.) For equipment fitted with internal

batteries you will find a 2nd battery switch used for measuring the battery voltage inside the top of the unit (3-pole circuit breaker.) To switch equipment power off completely you will also need to open this switch. Beware of possible residual charge in the capacitors inside the equipment and wait for 5 minutes so that they can discharge.

Procedure for passing from normal operation to maintenance bypass:

- Shut down the inverter. Through the keypad of the control panel ((3) from Fig.25), go down to "CNTL" submenu (screen 1.0), and select "OFF". You will get to screen 1.2, asking you to shut down the unit by pressing (ENT), see Fig.24.
- Remove the screws that attach the mechanical block (BL).
- Remove the mechanical block (BL) of the manual bypass switch (Q5) and set it to "On" position.
- Set the output switch (Q2) to "Off" position.
- Set the Battery Fuse Holder or battery switch (Q3) to "Off". In models with independent battery pack/s also turn Battery Fuse Holder (Q8) of each pack to "Off".
- Set the input switch (Q1a) to "Off" position.

The UPS is supplying output voltage directly from the mains through the manual bypass. The UPS is completely shut down and inactive.

5.4.3. TRANSFER TO NORMAL OPERATION

Procedure for switching from maintenance bypass to normal operation:

- In model with an external battery cabinet, set fuse holder switch from battery cabinet (Q8) to "On" position.
- Set the input switch (Q1a) to "On" position.
- Set the output switch (Q2) to "On" position.
- Make sure that the UPS is in bypass mode (green and yellow LEDs signal "bypass")
- Set the manual bypass switch (Q5) to "Off" position and refit the mechanical block (BL) and the screws (t2).

It is an essential requirement for safety to refit the mechanical block (BL), as this avoids dangerous usage of the UPS and the loads connected to it.

Start up the inverter. The startup operation will be initiated through the keypad of the control panel ((3) from Fig.25). Select "CNTL" and Press (ENT) into control



submenu (screen 1.0), and then select "ON" and Press **(ENT)** once. You will get to screen 1.1, asking you to start the unit up "yes" or "no". You can select "Yes" by pressing **(ENT)**.

The UPS supplies output voltage entirely protected against voltage variations, electric noise, etc.

Wait for alarm message to appear:

CLOSE BATTERY SWITCH

Battery fuse holder switch or switch from UPS (Q3) can only be turned "On" when the previous alarm message has been canceled.

DO NOT TRY to close any battery fuse holder switch at any other moment because this operation could damage the equipment and/or possibly cause accidents. They can only be turned on by following the quoted previous steps.

The UPS delivers output voltage that is protected against all power disturbances.

6. CONTROL PANEL AND DISPLAY DESCRIPTION

6.1. CONTROL PANEL PARTS

(1) (LEDs) LED indications:

- (a) Rectifier Input Voltage OK (green)
- (b) Unit on Bypass (orange)
- (c) Inverter is working (green)
- (d) Unit working from batteries -mains failure (red).
- (e) In case of any alarm of the unit (red)

(2) Graphic Display

(3) Keyboard

ENT "Enter" key. Confirmation of orders, program values
(or other specified functions)

← "Left" key for submenu navigation, or cursor displacement

→ "Right" key for submenu navigation, or cursor displacement

↗ "Up" key for menu page navigation, or digit modification

↘ "Down" key menu page navigation, or digit modification.

ESC "Escape" key. Return to previous screen, cancel/finish programming
(or other specified functions)

By pressing the "right" and "left" keys you will see the titles on the sub menus and can navigate between the different displays.

6.1.1. TOUCH SCREEN

The touch functionality of the screen can be used by touching the screen. Simply type with your finger on the appropriate fields or text.

6.2. BASIC FUNCTIONS OF KEYBOARD FROM SYNOPTIC

Through keys advance ↘ and return ↗, there is access to all the menus of the LCD panel, and being able to move from one to another.

Through keys right → or left ←, there is access to the screens of all the submenus of the LCD panel, being able to move from one to another with themselves.

Key **(ENT)**, has different purposes depending on the menu we are:

- Setting values. Press key **(ENT)** to activate the function setting, the Figures in the screen will blink. With keys **→←** the character to set is selected and with keys **↵↗** the value is selected. To confirm press **(ENT)**. Next field will blink, to continue doing settings proceed in the same way or press **(ESC)** to return to no-setting situation.
- Validation of orders or commands.

When pressing key **(ESC)** you will go back to the previous screen of any screen of any submenu, , unless you are in the **"Parameters"** menu and in the process of setting any of them. If so, by pressing the **(ESC)** key the value will stop blinking, and by pressing it a second time you will go back to the previous screen.

With the UPS in bypass mode, use the ESC button to cancel alarms. In this way the audible alarm is turned off.

Notes related with the screen map (see Fig. 27):

- Some screens have a certain number of **"-"** characters. Each screen represents one function so the maximum length of the field will be determined by the number of characters.
- Each screen is labeled with a number located in its right bottom corner. It is only included as a mere reference for its next description and explanation.

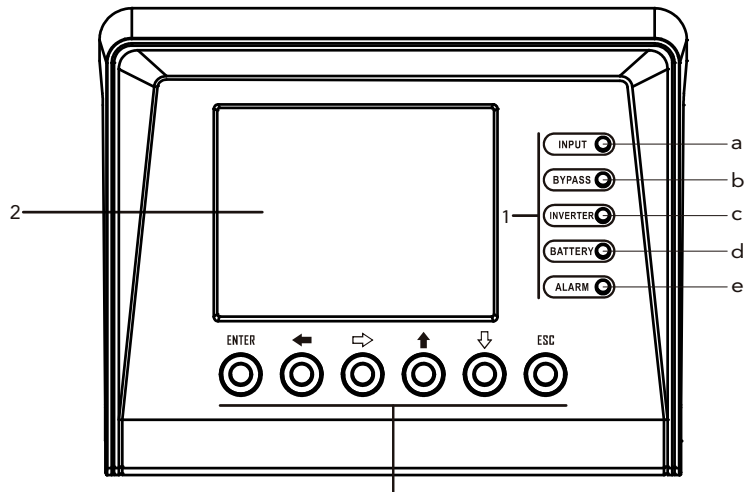

Fig.26: Control panel parts

6.2.1. MESSAGES MENUS AND CLASSIFICATION IN SUBMENUS

Use (←) (→) and (↔) (↔) keys to choose between different menus (1.0, ..., 5.0) and Press ENT to enter into the subscreen.

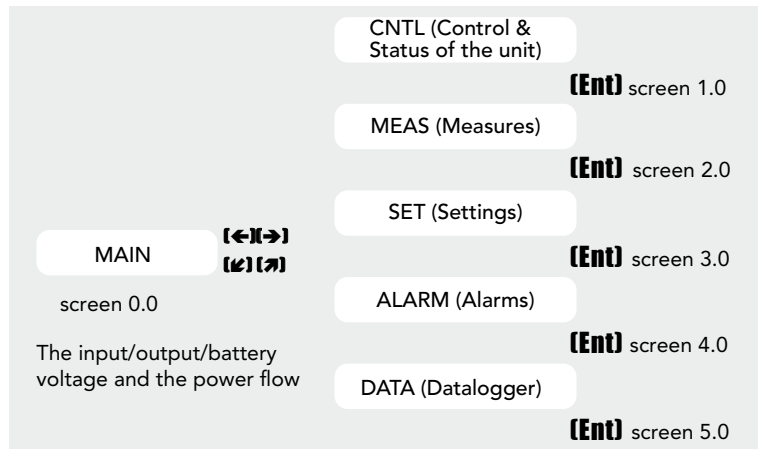
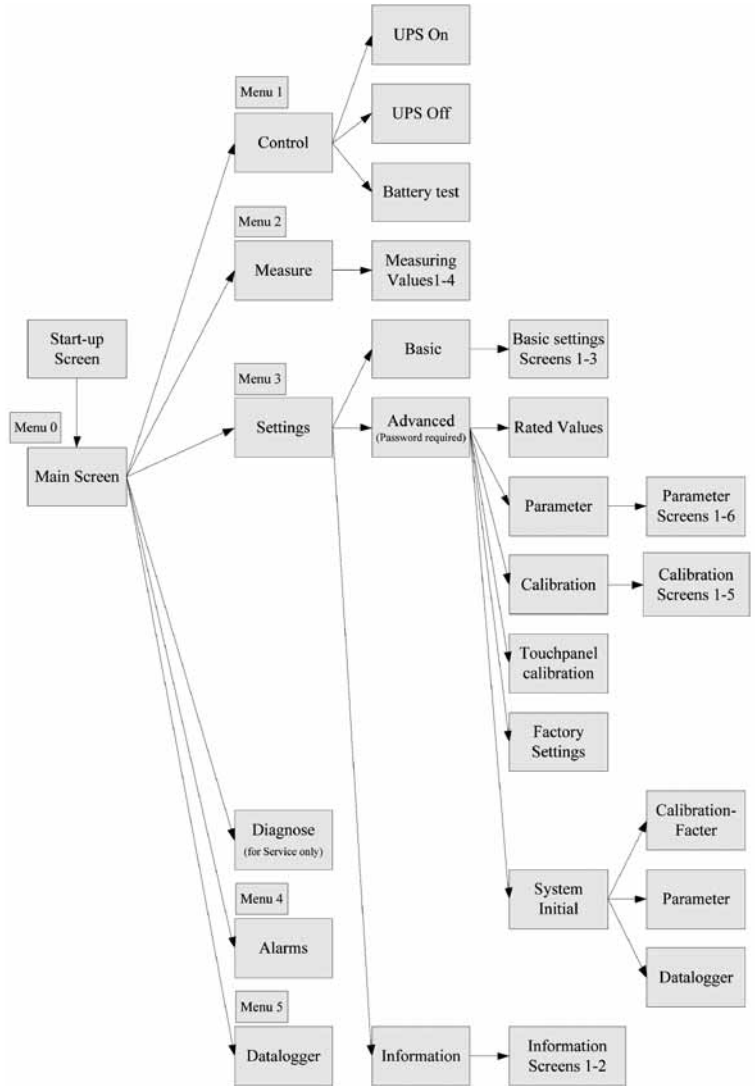

Fig.27: Display messages menus and classification in submenus.

6.2.2. MENU STRUCTURE



6.3. SCREEN DESCRIPTION

6.3.1. MAIN LEVEL (SCREEN MENU 0.0)

Screen 0.0:

Main presentation screen, with time and date indication.

Initialization: After power on

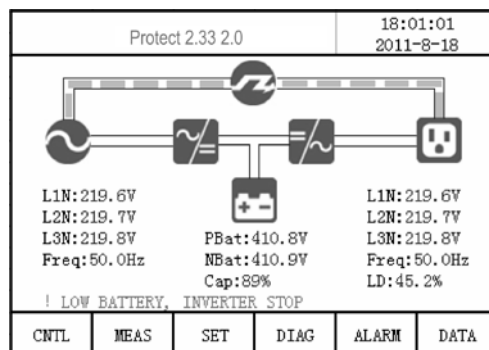

Use (ESC) key or Enter the Icon home  on any screen of any submenu, to go back to main screen (Screen 0.0).

Fig.28: Screen 0.0 Main Screen

6.3.2. UPS STATUS CONTROL (SCREEN MENU 1.0)

Screens 1.1 and screen 1.2:

Starting and switching off the equipment.

For how to start and switch off see chapter 5.1 and 5.2.

Screen 1.3:

Ordering a battery test. In the second row, information about the battery test is given.

Possible messages:

- "NOT AVAILABLE": The battery test is not available.
- "PRESS <ENTER>": Press <ENTER> to run the battery test.
- "EXECUTING": The battery test is running.
- "SUCCESSFUL": The battery test has been successful.
- "NOT SUCCESSFUL": The battery test has not been successful.

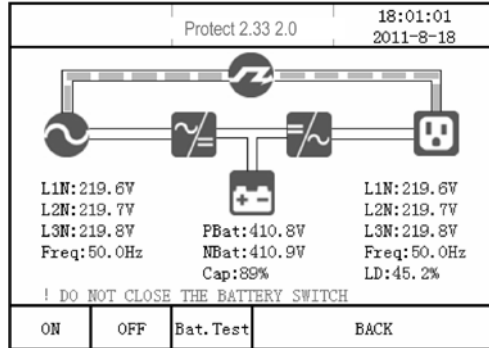

Fig.29: Screen 1.0 Control & status screen

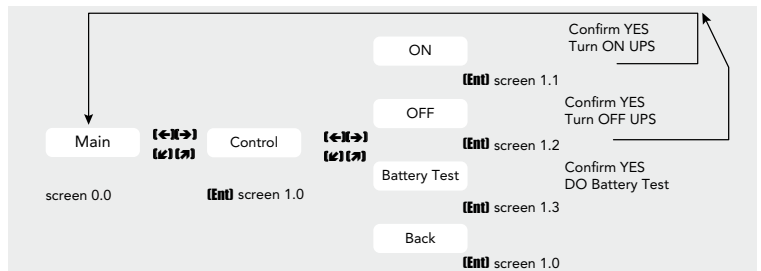
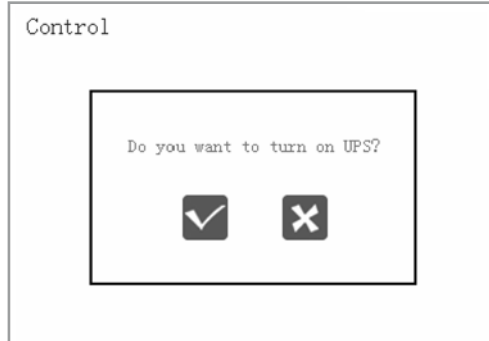
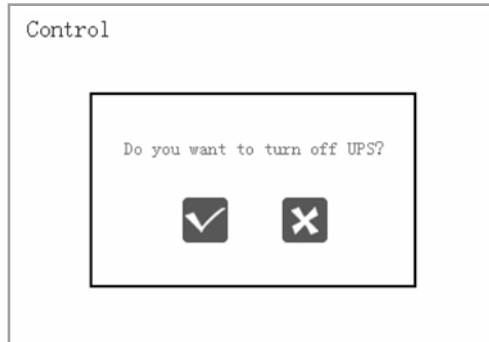

Fig.30: "Control & status" level



Screen 1.1 Turn on UPS



Screen 1.2 Turn off UPS

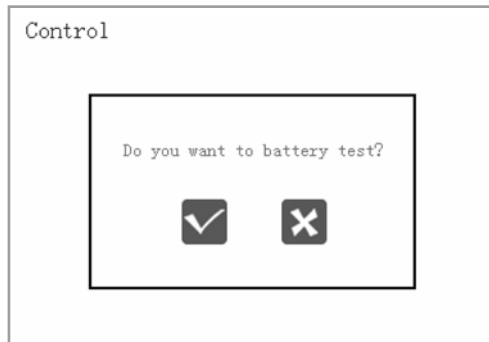

Screen 1.3 Battery Test

6.3.3. "MEASURES" LEVEL (SCREEN MENU 2.0)

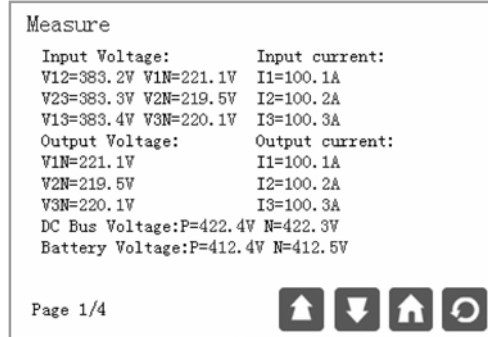

Screen 2.1:

- Input voltages phase to phase (display units 0.1 V)
- Three phase input voltages phases to neutral (display units 0.1 V)
- Input current per each phase (display units 0.1 A)
- Three phase output voltages phases to neutral (display units 0.1 V)
- Output current per each phase (display units 0.1 A)
- DC bus voltages positive and negative (display units 0.1 V)
- Battery voltages positive and negative (display units 0.1 V)

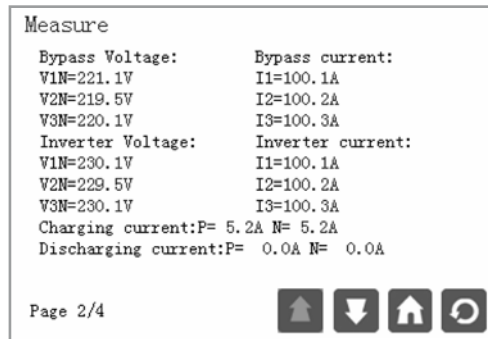

Screen 2.2:

- Three phase inverter output voltages phases to neutral (display units 0.1 V)
- Inverter output current per each phase (display units 0.1 A)
- Three phase bypass voltages phases to neutral (display units 0.1 V)
- Bypass current per each phase (display units 0.1 A)

- Charge battery currents positive and negative (display units 0.1 A)
- Discharge battery currents positive and negative (display units 0.1 A)

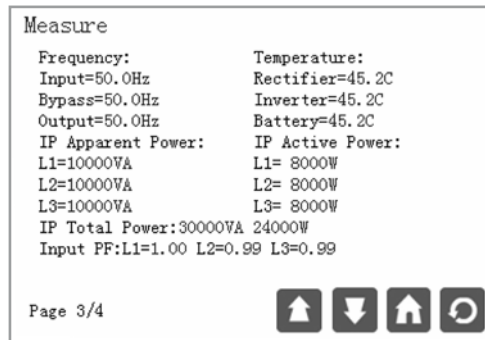

Screen 2.3:

- Input, bypass and output frequencies (display units 0.1 Hz)
- Rectifier, inverter and battery temperatures (display units 1 °C)
- Input apparent power of L1 (display units 0.1 kVA)
- Input apparent power of L2 (display units 0.1 kVA)
- Input apparent power of L3 (display units 0.1 kVA)
- Input active power of L1 (display units 0.1 kW)
- Input active power of L2 (display units 0.1 kW)
- Input active power of L3 (display units 0.1 kW)
- Total input apparent power and active power (display units 0.1 kVA & 0.1 kW)
- Input power factor per each phase (display units 0.01)

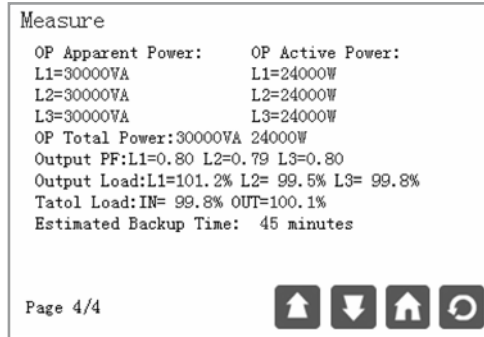

Screen 2.4:

- Apparent output power L1 (display units 0.1 kVA)
- Apparent output power L2 (display units 0.1 kVA)
- Apparent output power L3 (display units 0.1 kVA)
- Active output power L1 (display units 0.1 kW)
- Active output power L2 (display units 0.1 kW)
- Active output power L3 (display units 0.1 kW)
- Total apparent and active powers (display units 0.1 kVA and 0.1 kW)
- Output power factor of each phase (display units 0.01)
- Output load of three phases (display units 0.1 %)
- Total input load and total output load (display units 0.1 %)
- Calculated bridging time under the current load conditions (display unit intervals 1 minute)

6.3.4. "SETTINGS" LEVEL (SCREEN MENU 3.0)

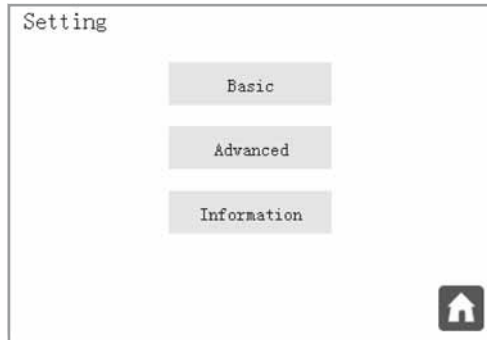
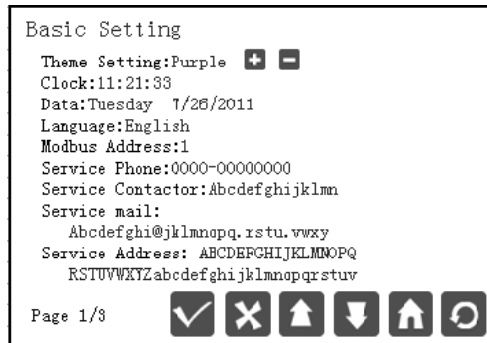

Fig.31: Screen 3.0 "Settings" and its submenus.



Screen 3.1: "Default settings"

The color scheme cannot be modified in the current software version.

Setting the time and date format

The following display languages are available :

- "German"
- "English"
- "French"
- "Spanish"
- "Czech"
- "Chinese"

The modbus address for communication over RS232/ 485 is fixed. In the current

software version this cannot be changed.

If not already entered by your AEG PS service team: Enter your service contact

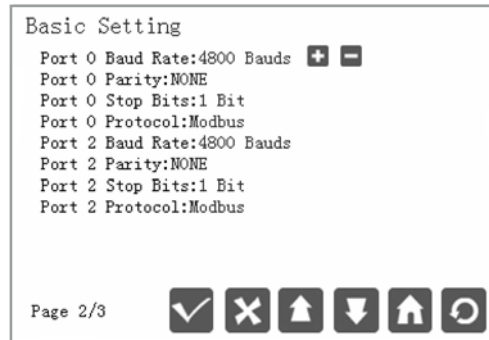

Screen 3.2:

In this screen you can program the baud rate of communication (port 0 and port 2). The options are the following

- "1200"
- "2400"
- "4800"
- "9600"
- "19200"

You can program the parity communication (port 0 and port 2). The options are the following:

- "NONE"
- "ODD"
- "EVEN"

You can program the number of stop bits communication (port 0 and port 2).

The options are the following:

- "1"
- "2"

You can program the protocol communication (port 0 and port 2). The options are the following:

- "SEC"
- "MODBUS"

Note: For problem free communication with the SNMP adapter and CompuWatch, you should not change the settings.

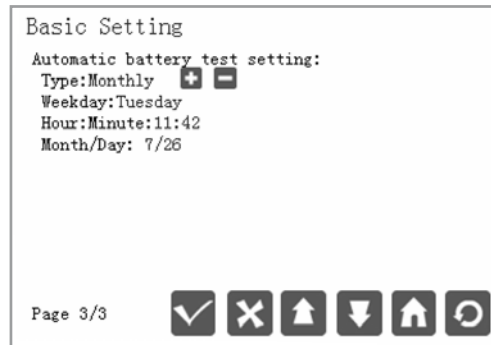

Screen 3.3:

The screen for programming the frequency of the automatic battery test. The options for the **Type** to be programmed are the following:

- “DISABLED”: The automatic battery test is disabled.
- “WEEKLY”: The automatic battery test runs once per week.
- “MONTHLY”: The automatic battery test runs once per month.
- “YEARLY”: The automatic battery test runs once per year.

For weekly testing choose a weekday. Choose from the following options:

- “MON”: The selected day to run the weekly battery test is Monday.
- “TUE”: The selected day to run the weekly the battery test is Tuesday.
- “WED”: The selected day to run the weekly the battery test is Wednesday.
- “THU”: The selected day to run the weekly the battery test is Thursday.
- “FRI”: The selected day to run the weekly the battery test is Friday.
- “SAT”: The selected day to run the weekly the battery test is Saturday.
- “SUN”: The selected day to the run weekly the battery test is Sunday.

Set the time here (24 h format).

For monthly testing choose a month and day for the battery test:

- “JAN”: The annual battery test will run in January.
- “FEB”: The annual battery test will run in February.
- “MAR”: The annual battery test will run in March.
- “APR”: The annual battery test will run in April.
- “MAY”: The annual battery test will run in May.
- “JUN”: The annual battery test will run in June.

- "JUL": The annual battery test will run in July.
- "AUG": The annual battery test will run in August.
- "SEP": The annual battery test will run in September.
- "OCT": The annual battery test will run in October.
- "NOV": The annual battery test will run in November.
- "DEC": The annual battery test will run in December.



Screen 3.4. "Advanced Setting"

In this section basic setting can be changed on the UPS. There is the risk that changes made can affect the function or cause damage to the UPS. Changes contained within this section should only be made by authorized personnel.

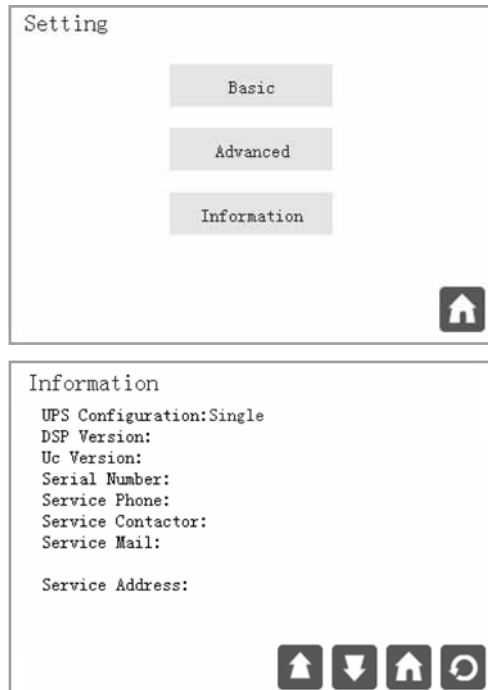

Screen 3.5 "Information"

In the screen "Information" you can check the UPS configuration of the unit.

Configuration and status of the unit:

- "Single" Single connection.
- "Parallel-Single" parallel connection. Unit is in "single" state.
- "Parallel-Master" parallel connection. Unit is in "master" state.
- "Parallel-Slave" parallel connection. Unit is in "slave" state.

Internal firmware versions of both Digital Signal Processor ("DSP Ver:") and micro controller ("uC Ver:").

UPS Serial Number, expressed with 10 characters.

Service information in the basic settings should be used.

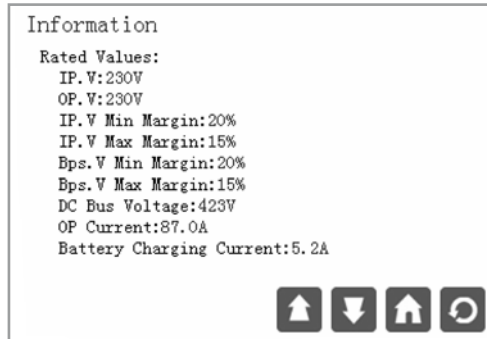

Screen 3.6

Information about the set-point values:

IP.V and OP.V shows the desired values for the input voltage at the rectifier and the output voltage.

In addition, you will see the maximum permissible voltage imbalance at the rectifier and the bypass input, the current at the output and the battery charging current. Furthermore, the current of the battery and the input will be displayed.

6.3.5. "ALARMS" LEVEL (SCREEN MENU 4.0)

When "Alarm" appears, in the main menu, you can only see one alarm, but you can enter "Alarm" into the menu' to check which alarms are in the current unit as in the following:

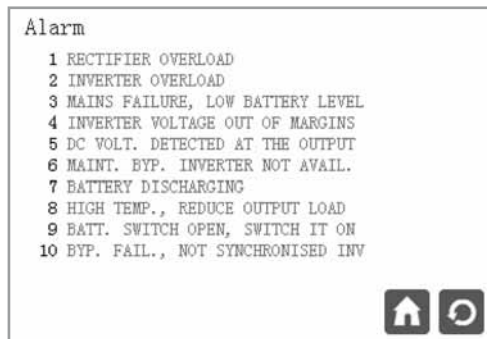

Screen 4.0 "Alarms

The illustration shows some examples of messages that may be displayed. Table 4 contains a list of all of the warning messages that can be displayed.

REPRESENTATION IN DISPLAY LCD	ALARMS FOR	NO.
Rectifier overload	Rectifier	1
Inverter overload		2
Mains failure, low battery level		3
Inverter voltage out of margins	Inverter	4
DC voltage detected at the output.		5
Maintenance bypass. inverter not available		6
Battery discharging		7
High temperature. Reduce output load.		8
Battery switch open. Switch it ON.		9
Bypass failure. Not synchronized inverter.		10
Unit on bypass. Initialise UPS.		11
Some unit(s) blocked due to maintenance bypass.		12
CAN BUS 1 Communication failure.		13
CAN BUS 2 Communication failure.	UPS	14
End of battery life.		15
Battery temperature too high.		16
Battery test not succeeded.		17
Battery disconnection. Shutdown & restart.		18
Mains phase rotation. UPS start disabled.		19
Bypass phase rotation. UPS start disabled.		20
EEPROM failure.		77
Input voltage wrong. Rectifier stop.		21
Rectifier desaturation. Rectifier stop.		22
DSP internal error. Rectifier stop.		23
Input phase rotation. Rectifier stop.	Rectifier stops	24
DC BUS voltage wrong. Rectifier stop.		68
Parallel system rectifier stop		69
Cont. Test fail rectifier stop.		75
Inverter desaturation. Inverter stop.		25
Inverter overload. Inverter stop.	Inverter stops	26

Inverter stopped due to shutdown		27
Maintenance bypass. Inverter stop		28
Parallel system disconnection. Inverter stop		29
High overload. Inverter stop		30
Over temperature. Inverter stop		31
Rectifier overload. Inverter stop	Inverter stops	32
DSP internal error. Inverter stop		33
Output short-circuit. Inverter stop		34
Bypass phase rotation. Inverter stop		35
Inverter failure/overload. Inverter stop		65
Voltage ramp error. Inverter stop		67
Parallel system inverter stop		70
Low battery. UPS stop		36
DSP internal error. UPS stop	UPS stops	37
PFC., Inv. stop UPS stop		71
Parallel system UPS stop		72
Emergency power off. No output voltage		38
Output short-circuit. No output voltage	Byp stops	39
DSP internal error. UPS block all		40
DC BUS voltage wrong. Rectifier block		41
Rectifier blocked. BLK. UPS -> BLK rec.		42
Rectifier desaturations. Rectifier block		43
Voltage ramp error. Rectifier block	Rectifier blocks	44
DSP execution error. Rectifier block		45
DSP internal error. Rectifier block		46
Contact test failure. Rectifier block		47
Voltage ramp error. Inverter block		48
Output DC voltage. Inverter block		49
Inverter blocked. BLK. UPS -> BLK inverter		50
Inverter desaturations. Inverter block	Inverter blocks	51
DSP execution error. Inverter block		52
DSP internal error. Inverter block		53
Inverter failure. Inverter block		66
UPS blocked. BLK. Rectifier -> BLK. UPS	UPS blocks	54

Internal initialization error. UPS block (DSP)		55
Internal execution error. UPS block (DSP)		56
UPS blocked. BLK. Inverter -> BLK. UPS		57
Internal communication. UPS block (DSP)		58
Parallel system discharging. UPS block		59
UPS over temperature. UPS block.	UPS blocks	60
Rectifier overload. UPS block		61
Inverter desaturations. UPS block		62
DSP internal error. UPS block		63
PFC & inverter blockage. UPS block		64
Paral. coms error UPS block		76
Error coms. paral. master fixed	Parallel	73
Alarm paral. sist. redundancy lost		74

Table 4: Alarm list displayed in the LCD panel

Alarm 1:

This message indicates that the rectifier is overloaded. The rectifier overload appears when the input current of any phase is greater than the following ratio:

$$I_{in-ovl} = 0.326 \times P_{out} / V_{out_p-n}$$

Where

- I_{in-ovl} is Overload Input Current (A)
- P_{out} is Rated Output Apparent Power (VA)
- V_{out_p-n} is Rated Output Voltage phase-to-neutral (V)

Alarm 2:

This message indicates that the inverter is overloaded. The inverter overload appears either when the output current of any phase is greater than the rated output current

$$I_{out-ovl} = P_{out} / (V_{out_p-n} \times 3)$$

Where:

- I_{out} is rated Output Current (A)
- P_{out} is Rated Output Apparent Power (VA)
- V_{out_p-n} is Rated Output Voltage phase-to-neutral (V)

or when the total output active power is greater than the following formula:

$$\text{Pact_out-ovl} = \text{Pout} \times 0.8$$

Where:

- Pact_out-ovl is the Overload Output Active Power (W)
- Pout is Rated Output Apparent Power (VA)

Alarm 3:

This alarm appears when the input the unit is under main failure condition and the level of battery is lower than 11.5 V/battery pack

Alarm 4:

This alarm appears when the inverter output voltage phase to neutral in any phase is out of margins over $\pm 6\%$.

Alarm 5:

This alarm appears when there is an offset voltage higher than 5 V, in any phase of the inverter output voltage phase to neutral.

Alarm 6:

When the maintenance bypass switch is ON the UPS inverter will not be available.

Alarm 7:

The mains failure occurs when in any phase, the input voltage phase to neutral is out of the set margins (+15 %/-20% by default) or the input frequency is out of the set margins (± 5 Hz by default).

Alarm 8:

When the inverter or PFC temperature sensors measure temperatures over the programmed values (70 °C by default).

Alarm 9:

This message appears when the battery switch is OFF and the DC bus is charged to the battery voltage level, to inform the user to switch ON the battery switch.

Alarm 10:

This Alarm indicates that the bypass input voltage or the bypass input frequency are out of margins. These margins are programmable but by default the bypass voltage range is +12 %/-17 % and the bypass frequency range is ± 2 Hz.

Alarm 11:

The UPS is on bypass for any reason. It must be restarted by display keypad.

Alarm 12:

This is an alarm for parallel systems. It appears when some UPS of the parallel system block because the maintenance bypass switch of any unit is switched ON.

Alarm 13:

This alarm indicates that the CAN BUS #1 fails. This communication channel is used for remote control.

Alarm 14:

This alarm indicates that the CAN BUS #2 fails. This channel is used for data communication between UPS, in a parallel system.

Alarm 15:

This alarm appears at the estimated end of life of the battery bank. The revision and replacement of some batteries will be necessary to be done via AEG PS customer service.

Alarm 16:

The temperature of battery cabinet (in case of separate battery cabinet) or battery place (in case of battery are located inside the UPS) is higher than 40 °C.

Alarm 17:

If battery test (automatic or manual) is finished unsuccessfully, this alarm will appear.

Alarm 18:

Two possible reasons:

- During the unit start up, a message appears indicating that the battery switch can be switched ON. After some period of time without switching ON, this alarm appears.
- When the unit is running under normal conditions, and the battery switch is switched OFF.

Alarm 19:

When the mains is connected during the start up, a phase rotation error is detected and the start up procedure is inhibited.

Alarm 20:

When the bypass is connected during the start up, a bypass phase rotation error is detected and the start up procedure is inhibited.

Alarm 21:

This alarm appears when in any phase, the rectifier input voltage phase to neutral is out of the set margins (+15 %/-20 % by default) or the rectifier input frequency is out of the set margins (± 5 Hz by default). Then the rectifier is shut down.

Alarm 22:

This message appears when the protection circuit is activated to prevent overload of the IGBT rectifier.

Alarm 23:

This message appears when an internal error in the digital signal processor (*) DSP occurs in the rectifier module. The rectifier is shutdown immediately. The UPS will make 3 attempts to restart, then the rectifier will be blocked.

Alarm 24:

When a mains phase rotation error is detected and under these conditions the rectifier is tried to be turned ON, an input phase rotation alarm appears shutting down the rectifier.

Alarm 25:

This message appears when the protection circuit for the avoidance of DC inverter-IGBT overload is active.

Alarm 26:

This message appears when the inverter becomes overloaded (> 100%).

Alarm 27:

When an external shutdown signal is enabled, the inverter will shut down appearing this message.

Alarm 28:

When the inverter is running and the maintenance bypass switch is turned ON the inverter shuts down immediately.

Alarm 29:

This alarm appears when, in a parallel system, one UPS goes to battery mode. The inverter will shut down.

Alarm 30:

This message appears when a parallel system has a UPS shutdown due to high voltage.

Alarm 31:

When an over temperature is detected by the PFC or inverter temperature sensors, after 1 minute time the inverter will be turned off automatically. If over temperature condition remains after another 1 minute with the rectifier working, rectifier is also blocked (alarm 60).

Alarm 32:

When the rectifier is overloaded, depending on the level of this overload, the inverter will be shut down after some time according to the rectifier overload curve and this alarm will appear. If this overload is still present with the inverter switched off, the rectifier will be blocked after 30 seconds and blocking alarm 61 will appear.

Alarm 33:

This message appears when an internal error in the digital signal processor (*) DSP in the AC rectifier module occurs. The inverter will shut down immediately. Four attempts will be made to restart the UPS, then the inverter will be blocked.

Alarm 34:

This alarm appears when an output short-circuit is detected limiting the output RMS current up to the set value (150 % of nominal current by default). The short-circuit is detected when the output voltage phase to neutral is lower than 8 % of nominal voltage. The system will retry twice to restart.

Alarm 35:

With the inverter is running, if there's a bypass phase rotation error, the inverter will shut down.

Alarm 36:

This alarm appears when there is a (*) DSP Internal Error in the UPS module, shutting down the UPS immediately. There will be 2 more retries before the UPS blocking.

Alarm 37:

This alarm describes that on battery mode, the battery bank reaches the 10.5 V/battery pack This is the end of backup time, shutting down the UPS.

Alarm 38:

The EPO (Emergency Power Off) switch is ON. The UPS and the static bypass are switched off and no AC voltage present at the output anymore.

Alarm 39:

This message appears when, despite the three attempts to start up the UPS, a short circuit is still detected at the output. UPS and static bypass switch are turned off, there is no voltage at the output.

Alarm 40:

This alarm appears when there is a (*) DSP Internal Error in the UPS module, for three times shutting down the UPS. The UPS blocks including the bypass, so no AC voltage present at the output anymore.

Alarm 41:

This alarm appears when there is one of the following conditions:

- Positive DC bus voltage over 450 V.
- Positive DC bus voltage less than 325 V.
- Negative DC bus voltage over -450 V (absolute value).

Alarm 42:

This alarm appears when the UPS is blocked for any reason. This condition blocks also the rectifier.

Alarm 43:

This message appears when, at the rectifier, the protection circuit has been tripped three times in order to prevent a rectifier-IGBT overload. The rectifier is now blocked.

Alarm 44:

If an error in the initial rectifier ramp is detected during the PFC start up (Soft-Start), this alarm will appear blocking also the rectifier.

Alarm 45:

There is a command from the microprocessor to the DSP, with no response from the rectifier module of the DSP. The rectifier will block.

Alarm 46:

After 4 times shutting down the rectifier because of (*) DSP Internal Error in the rectifier module, this alarm will appear indicating rectifier blocked.

Alarm 47:

During the start up there is an input contactor test. If this test ends unsuccessfully the rectifier will be blocked.

Alarm 48:

If the output voltage ramp doesn't work properly during the inverter start up the inverter will be blocked (See alarm 67).

Alarm 49:

This alarm appears when there is an offset voltage higher than 8 V, in any phase of the inverter output voltage phase to neutral. Then the inverter will be blocked.

Alarm 50:

This alarm appears when the UPS is blocked for any reason. This condition blocks also the inverter.

Alarm 51:

If the inverter protective circuit to prevent overload IGBT inverter has been activated, this message appears. The inverter is now blocked.

Alarm 52:

There is a command from the microprocessor to the DSP, with no response from the inverter module of the DSP. The inverter will block.

Alarm 53:

After 5 times shutting down the inverter because of (*) DSP Internal Error in the inverter module, this alarm will appear indicating inverter blocked.

Alarm 54:

This message appears when a blockage of the rectifier and the UPS has occurred.

Alarm 55:

The alarm appears when the DSP doesn't response to the microprocessor during the initial procedure before the start up.

Alarm 56:

There is a command from the microprocessor to the DSP, with no response from the UPS module of DSP. The UPS will block.

Alarm 57:

This message appears when a blockage of the inverter and the UPS has occurred.

Alarm 58:

There is an internal error in the communication channel between microprocessor and DSP. This condition blocks the UPS.

Alarm 59:

This alarm appears when, in a parallel system, one UPS goes to battery mode. After some period of time, the UPS will shut down.

Alarm 60:

When an over temperature is detected by the PFC or inverter temperature sensors, first the inverter will be turned off automatically after 1 minute time (alarm 31). If one minute later the over temperature is still detected, the UPS will be completely blocked (rectifier also shut-down) and the alarm appears.

Alarm 61:

This message appears if the rectifier is overloaded, depending on the magnitude and duration of the overload, the inverter is switched off. If the inverter is switched off and the overload persists, the UPS is completely blocked for 30 seconds (rectifier is also shut down.)

Alarm 62:

This message appears if the protection circuit to prevent IGBT overload has been activated and the inverter has been turned off. The UPS will make 2 attempts to restart the inverter. If the protection circuit is again activated, the UPS will be blocked.

Alarm 63:

After 3 times shutting down the UPS because of (*) DSP Internal Error in the UPS module, this alarm will appear indicating UPS blocked.

Alarm 64:

This message appears if the inverter and power factor correction filter (PFC) are blocked, the UPS will also be completely blocked.

Alarm 65:

This alarm can be activated due to a connection of a load with high inrush current, or also, if it is detected a wrong transient voltage in the inverter (i.e., if there is a fault in an inverter transistor). In such case, the inverter will be shutdown for while and load will be transferred to bypass immediately. The equipment will retry to start up the inverter several times (see description of the Alarm 66 too).

Alarm 66:

After several attempts detecting "Inverter Fault/Overload" (see Alarm 65), the inverter will be blocked permanently, and output will be transferred to bypass.

Alarm 67:

The way to start up the inverter is on voltage ramp mode (rms value from sine wave voltage starts at 0 Vrms till reaching its preset nominal value, i.e., 230 Vrms). If when doing the voltage ramp is detected any fault, the inverter will be shutdown for while, and it will retry to start it up several times (see description of the Alarm 48 too).

Alarm 68:

When a high or low DC bus voltage is detected, rectifier is shutdown for a while, in order to retry to start up later on (see description of Alarm 41 too).

Alarm 69:

In parallel system, rectifiers from the equipment of the system connected in parallel can be shutdown, due to the management of system as a whole, therefore this alarm is activated.

Alarm 70:

In a parallel system, the inverters of the equipment of the system connected at the output can be shutdown, due to the management of system as a whole, therefore this alarm is activated.

Alarm 71:

This alarm is displayed when a combined shutdown of the PFC-rectifier and inverter has been done at the same time (there are several reasons).

Alarm 72:

This message is displayed if there has been a simultaneous shutdown in a parallel systems rectifier and inverter.

Alarm 73:

In parallel mode, this message appears when a communication error in the redundant parallel communication has occurred. Possible reasons for this are parallel communication cable separation, incorrect connection, incorrect configuration of the devices etc. In this case one of the devices should be defined as a master and the others as permanent slaves. This state is maintained until the fault is cleared and the UPS system is rebooted.

Alarm 74:

In a parallel system, with N+M configuration, where:

N: nr equipment to size the system according to the maximum permissible load.

M: nr redundant equipment in the system. It is equivalent to over sizing the UPS's in the system, in order to continue supplying the maximum permissible load without overloading it. Usually, this value is fixed to "1".

The alarm is displayed when the load exceeds the maximum permissible load by N equipment. In this condition, the equipment will not be overloaded individually, meanwhile the load doesn't exceed the maximum load of N+M.

Example: Assuming that a parallel system of 2+1 equipment of 20 kVA (N=2, M=1).

If the load of the system is lower than 40 kVA.

Any overload alarm is displayed (if it is not exceeded the individual overload for phase for each equipment).

If the load of the system is higher than 40 kVA. The alarm 74 "Loss of redundancy" is displayed.

If the load of the system is higher than 60 kVA. Beside the alarm 74 "Loss of redundancy", there will also be (as a minimum, among others), alarm 2 "Inverter overload" in all the equipment in the system.

Alarm 75:

This alarm can be displayed for two reasons:

Input contactor from the equipment faults (it doesn't close properly). It is shown when the DC bus voltage is not kept at a certain level when closing the input contactor. Input contactor from the equipment fails (it doesn't close properly).

The system can retry the contactor test several times (see description of alarm 47).

Alarm 76:

After the first error in the parallel system communication, when one of the UPS's has already been chosen as a master in the system, a second error or break in the communications has been detected by the slave equipment, which will be blocked permanently (rectifier and inverter are shutdown, output voltage is not supplied to the output of the system), by displaying this alarm.

Alarm 77:

Error in configuration memory.

(*) DSP internal error can happen for the following reasons:

- Watchdog failure.
- Wrong ADC measures.
- Communication errors between DSP and processor.

6.3.6. "DATA LOGGER" LEVEL (SCREEN MENU 5.0)

```

Data Logger
Hours Inverte On:0000 0145
1 Inverter Overload

Alarm On time:09:27:35-26/07/2011
Alarm Off time:09:30:35-26/07/2011
State:
  Rectifier:Run
  Inverter:Run
  Bypass:Initialize
  Unit:Ups Run
  Flags:04
  
```



The image shows a screen titled "Data Logger" with the following text: "Hours Inverte On:0000 0145", "1 Inverter Overload", "Alarm On time:09:27:35-26/07/2011", "Alarm Off time:09:30:35-26/07/2011", "State:", "Rectifier:Run", "Inverter:Run", "Bypass:Initialize", "Unit:Ups Run", "Flags:04". At the bottom right, there are four icons: an up arrow, a down arrow, a home icon, and a refresh icon.

Fig.32: Screen 5.0 "Data logger"

The first line indicates the inverter runtime from the first unit startup. This counter accumulates the total inverter running time from the beginning; it is not possible to reset it.

Using the (⬅), (➡) keys, you can move throughout the different registers of this historic file. The data logger file can save up to 100 historic registers.

Alarm on and off time.

The first row displays the date and time when the alarm occurred:

- hh: hour of alarm activation
- mm: minutes of alarm activation
- ss: seconds of alarm activation
- dd: day of alarm activation
- mm: month of alarm activation
- yy: year of alarm activation

The second row displays the date and time when the alarm was deleted:

- hh: hour of deleted alarm
- mm: minutes of deleted alarm

- ss: seconds of deleted alarm
- dd: day of deleted alarm
- mm: month of deleted alarm
- yy: year of deleted alarm

The state for technical service, to understand the condition of the different parts of the UPS at the moment the registered alarm was activated.

7. MAINTENANCE, WARRANTY AND SERVICE

7.1. BASIC MAINTENANCE GUIDE

Batteries, fans and capacitors must be replaced at the end of their useful lifetime.



Inside the UPS there are dangerous voltages and metallic parts at very high temperatures, even though the UPS may be shut down. Any direct contact can cause electrocution and burns. All the operating, apart from battery fuse replacement, must be done by authorized technical staff.



Some internal parts of the UPS (terminals, EMC filters and measurement circuits) are still under voltage during maintenance bypass operations. To cancel all the voltages, the mains and bypass circuit breakers on the panel that feeds the UPS and the fuse holders of the external battery cabinet have to be turned "OFF" / "0". The internal batteries must also be isolated from the system. Together with this, the 3-pole circuit breakers for measuring the battery voltage located within the upper part of the equipment is released.

7.1.1. BATTERY FUSES

There is significant risk if an attempt to switch either the battery switch or fuse box switch ("ON" or "I") before the message "Battery Switch Connect" appears in the display, an arc may result and the switch destroyed.

Replace defective battery fuses only with fuses of the same type rating.



7.1.2. BATTERIES

Battery life depends largely on how the batteries are used (partial or full discharge, number of cycles) and on the ambient temperature.

With the use of batteries in an unsuitable condition or in incorrect numbers there is a risk of fire or explosion.



Do not dispose of batteries in fire, they may explode. Do not open or damage batteries, battery acid is toxic and can cause chemical burns to skin and eyes.

7.1.3. COOLING FAN

The lifespan of the cooling fan will depend on the usage and environmental conditions. It is recommended that you replace the fan as part of the service contract on a regular basis and using authorized technical personnel.

7.1.4. CAPACITORS

The useful lifetime of the DC bus capacitors and those used in input and output filtering depends on their use and the environmental conditions. It is recommended that preventive replacement be carried out by authorized technical staff.

7.2. WARRANTY CONDITIONS

Changes in these operating instructions, particularly as regards technical data and operating instructions can occur at any time and without notice.

If damage occurs due to not following the instructions, any warranty claim will be void. AEG PS accept no responsibility for consequential damage.

AEG PS reserves the rights to cancel this agreement or that entered into by its dealers at any time and without prior notice if other than original AEG PS or AEG related spare parts are used for maintenance and repair.

8. ANNEXES

8.1. GENERAL TECHNICAL SPECIFICATION

TABLE 5: TECHNICAL SPECIFICATION

Capacity (kVA/kW)	10/8	15/12	20/16	30/24	40/32	60/48	80/64
INPUT							
Acceptable voltage range	3 x 400 V (3 Ph + N), +15 % to -20 %						
Frequency (Hz)	50/60 ±5 %						
Nominal input current	13 A	20 A	26 A	39 A	52 A	78 A	103 A
Total harmonic distortion (THDi)	<1.5 % @ 100 % load <2.5 % @ 50 % load <6.0 % @ 10 % load			<1.0 % @ 100 % load <2.0 % @ 50 % load <5.0 % @ 10 % load			
Power factor	1.0 (from ca.10 % charge)						

INVERTER

Nominal voltage	3 x 400 V (3 Ph + N)						
Precision (%)	stationary: ±1, transitory: ±2 (load variations 100-0-100)						
Frequency (Hz)	50/60 ±0.05 %, without mains						
Synchronisation speed	±1 Hz/s						
Waveform	sine wave						
Total harmonic distortion	<0.5 % (linear load), <1.5 % (non-linear load)						
Phase displacement	±1 % (balanced load), ±2 % (50 % unbalanced load)						
Dynamic recovery time	10 ms (98 % of static value)						
Admissible overload	125 % for 10 min., 150 % for 60 s						
Admissible crest factor	3.4 : 1			3.2 : 1			
Admissible power factor	0.1 inductive to 0.1 capacitive						
Imbalance output voltage @ 100 % unbalanced load	<1 %						
Current limitation	3 x I _{nom} (short circuit)						
Inverter efficiency (%)	94.5	95.0	95.3	95.9	96.2	96.4	96.6

STATIC BYPASS

Type	Thyristor
Voltage	3 x 400 V (3 Ph + N)
Frequency (Hz)	50/60
Control	microprocessor controlled
Transfer time	uninterrupted
Admissible overload	400 % for 10 s
Transfer to bypass	immediate (for overloads >150 %)
Retransfer	automatic after alarm clear

MAINTENANCE BYPASS

Type	without interruption
Voltage	3 x 400 V (3 Ph + N)
Frequency (Hz)	50/60

GENERAL

Max. charging current	23.5 A		47.0 A			70.5 A	
Overall efficiency (online mode) (up to %)	91	91.3	92	92.4	93.1	93.6	94.3

MASS/WEIGHT/AUTONOMY TIME

Dimensions approx. D x W x H (mm)	700 x 450 x 1.100			805 x 590 x 1.320			
Footprint (m ²)	0.315			0.475			
Net weight (without batteries) kg	110			180		210	230
Integrated battery type (2 x 31)	12 V 7 Ah	12 V 7 Ah	12 V 9 Ah	12 V 12 Ah	12 V 18 Ah	-	
Autonomy time (min.)	15	10	9	8	9	-	
Weight with integr. battery approx. (kg)	250		270	397	542	-	

TABLE 6: EXTERNAL BATTERY CABINET

DIMENSIONS & WEIGHT EXTERNAL BATTERY CABINET

Capacity (kVA/kW)	10/8	15/12	20/16	30/24	40/32	60/48	80/64
	No. 1			No. 3			
Dimensions approx. D x W x H (mm)	700 x 450 x 1100			805 x 590 x 1320			
Integrated battery type (2x31)	12 V 12 Ah			12 V 26 Ah			-
Autonomy time (min.)	32	20	14	20	14	8	-
Net weight approx. (kg)	250			710			-
	No. 2			No.4			
Dimensions approx. D x W x H (mm)	700 x 450 x 1100			980 x 650 x 1322			
Integrated battery type (2x31)	12 V 18 Ah			12 V 40 Ah			
Autonomy time (min.)	57	34	24	40	25	15	10
Net weight approx. (kg)	410			1020			

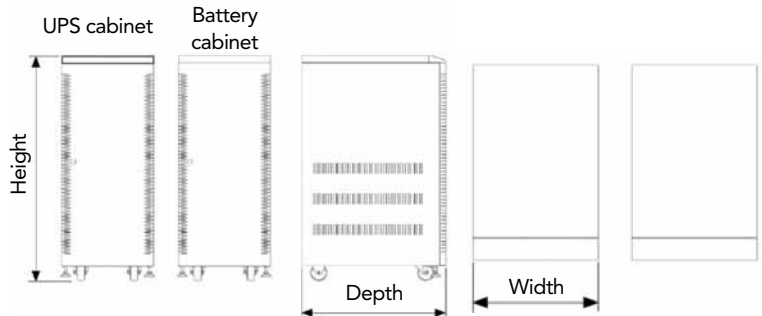

Cabinet No. 4 has no wheels

Fig.33: General technical specifications.

8.2 SAFETY INSTRUCTIONS





1. To provide for

- These “Safety Instructions” are associated with the “Operating Manual” regarding the equipment you have purchased. Before proceeding with the installation or the startup, read the safety instructions carefully. Compliance with the “Safety Instructions” is obligatory, observance of this being the user’s legal responsibility. Follow the steps mentioned in the established order. Retain them for future consultation. The local electrical standards and different restrictions of the end user geographical location may invalidate some of the recommendations given in the manuals. In case of discrepancies, the user must comply with the pertinent local standards. It is possible to come across equipment where the distribution of the connecting terminals and/or commands do not align with the manual’s illustrations. However, the simplicity of operation together with the labeling permits easy understanding.
- It is strictly forbidden to reproduce or to release this information without the written permission from our company.
- Do not install the machine in a corrosive or dusty atmosphere and never out of doors.
- Do not obstruct the ventilation grilles nor introduce objects through these or other openings. Leave a minimum free space of 25 cm around the machine for ventilation and air circulation.
- Locations must be spacious, well ventilated, away from any heat sources and easy to access. In addition to the ventilation space indicated above, there must be an area of 75 cm free all around the equipment to allow access for after sales service personnel.
- Do not place materials on top of the machine or objects which would obstruct view of the synoptic reading.



2. General Safety Instructions

- All equipment connections including those of the control, should be done without the presence of the mains supply and with the switches turned to the off, position “O”, “Off”,  or .
- Special attention should be given to the labeling on the equipment warning about the “Risk of electric shock” and indicators like . Hazardous live parts inside the equipment, do not remove the cover. Servicing should only be carried out by qualified service personnel. For maintenance or repair service, please contact your nearest after sales service from AEG Power Solutions is compulsory

to connect the protection earth, ensure that this is correctly installed before powering up the input to the equipment.

- The installation of UPS equipment should only be carried out by qualified personnel experienced in low voltage installations.
- The cross section of the power supply and output cables to the loads should be determined according to the rated current given on the equipment's specifications plate and complying with the local low voltage electro technical regulations.
- The power supply cables to the equipment as well as to the loads, interfaces, etc. should be fixed to non-movable parts.
- The neutral cable must be connected only with the clamp provided. Note that all neutral cables for input, output and the center tap of the battery inside the UPS are connected together. The UPS works without a transformer. A leakage current of 160 mA can occur.



3. Safety interactions for battery equipped products

- A UPS is a continuous power supply equipment. If the mains supply fails while the equipment is operating, the output lines will continue to supply output voltage depending on the autonomy times provided by the batteries.
- The 10 – 40 kVA UPS can be delivered with built in batteries. Optionally batteries can be delivered separately and then installed at your location by authorized personnel.
- For proper operation the battery cabinet must be located beside the machine.
- The battery supply can involve the risk of electric shock and can produce high short circuit current. Observe the following preventive measures before manipulating any terminal block identified in the labeling as "Battery".
 - Disconnect the corresponding protection elements.
 - When connecting a battery cabinet with the equipment, respect the cable's polarity and color (red-positive; black-negative) indicated in the manual and in the corresponding labeling.
 - Wear rubber gloves and shoes.
 - Use tools with insulated handles.
 - Removes watches, rings or other metal objects.
 - Do not place metal tools or objects on the batteries.
 - Never manipulate with your hands through conducting objects, do not short the battery terminal block or the battery enclosure.

- When the equipment will be stored for long periods, it is recommended that the batteries are separated from the UPS so that they can be charged.
- When the equipment will be stored for long periods, it is recommended that the batteries be charged monthly in order to maintain the efficiency of the batteries.

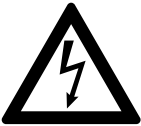

4. Safety instructions regarding the batteries.

- Never short the battery terminals as it involves a high risk. It will result damage to the equipment and the battery.
- Avoid mechanical exertion and impact.
- Do not open or mutilate the battery. Released electrolyte is harmful to the skin and eyes.
- Do not dispose of a battery in a fire. The battery may explode.
- In case of contact between acid and parts of the body, wash affected area immediately with plenty of water and call the nearest medical service.
- Batteries involve a serious risk for to health and for the environment. Their disposal should be carried out according to existing local laws.

WARRANTY

MODEL: _____

SERIAL NUMBER: _____

PURCHASE DATE: _____

DEALER STAMP/SIGNATURE

ERRORS AND TECHNICAL MODIFICATION SUBJECT TO CHANGE.

OPERATING INSTRUCTIONS
8000032013 BAL, EN

AEGPS - Protect 2.33 2.0 - EN - 07/2012 V1 - Due to our policy of continuous development, the data in this document is subject to change without notice.
AEG is a registered trademark used under licence from AB Electrolux.